

# 2RI60E(2x60A)

## POWER DIODE MODULE

600V,800V / 60A

2 in one-package

### ■ Features

- Glass Passivation Chip
- Easy Connection
- Insulated Type

### ■ Applications

- Inverters
- Battery Chargers
- DC Motors
- General Purpose DC Power Supplies

### ■ Outline Drawings, mm

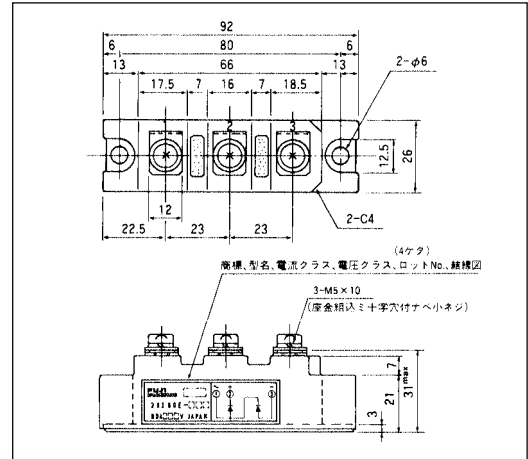

### ■ Inner Circuit Schematic

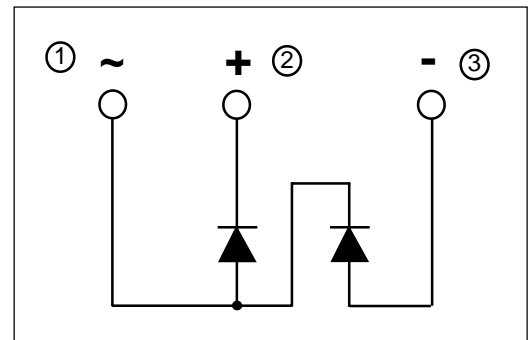

### ■ Maximum ratings and characteristics

#### ● Absolute maximum ratings

Item	Symbol	Conditions	Rating		Unit
			-060	-080	
Repetitive peak reverse voltage	$V_{RRM}$		600	800	V
Non-repetitive peak reverse voltage	$V_{RSM}$		660	880	V
Average output current	$I_O$	50/60Hz Sine wave, $T_c=113^{\circ}\text{C}$	2 x 60		A
Surge current	$I_{FSM}$	From rated load, Sine wave 10ms	1200		A
$I^2t$	$I^2t$	From rated load	6000		$\text{A}^2\text{s}$
Operating junction temperature	$T_j$		-40 to +150		$^{\circ}\text{C}$
Storage temperature	$T_{stg}$		-40 to +125		$^{\circ}\text{C}$
Isolation voltage	$V_{is}$		AC2000(1min.)		V
Screw torque			3.5	*1	N·m

\*1: Recommendable value : 2.5 to 3.0 N·m(M5)

#### ● Electrical characteristics ( $T_a=25^{\circ}\text{C}$ Unless otherwise specified)

Item	Symbol	Conditions	Min.	Typ.	Max.	Unit
Forward voltage drop	$V_{FM}$	$T_j=25^{\circ}\text{C}$ , $I_{FM}=190\text{A}$			1.30	V
Reverse current	$I_{RRM}$	$T_j=150^{\circ}\text{C}$ , $V_R=V_{RRM}$			20	mA

#### ● Thermal Characteristics

Item	Symbol	Conditions	Min.	Typ.	Max.	Unit
Thermal resistance	$R_{th(j-c)}$	Junction to case			0.25	$^{\circ}\text{C}/\text{W}$
	$R_{th(c-f)}$	the base to cooling fin *			0.10	$^{\circ}\text{C}/\text{W}$

\* : With Thermal Compound

Characteristics

Forward Characteristics

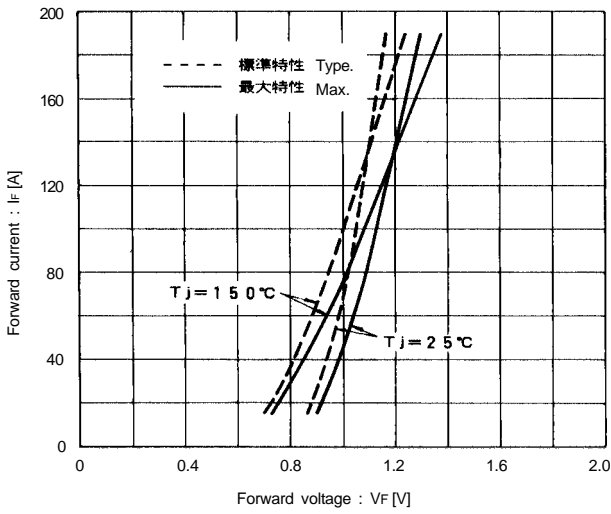

Forward Average Current vs. Power Loss

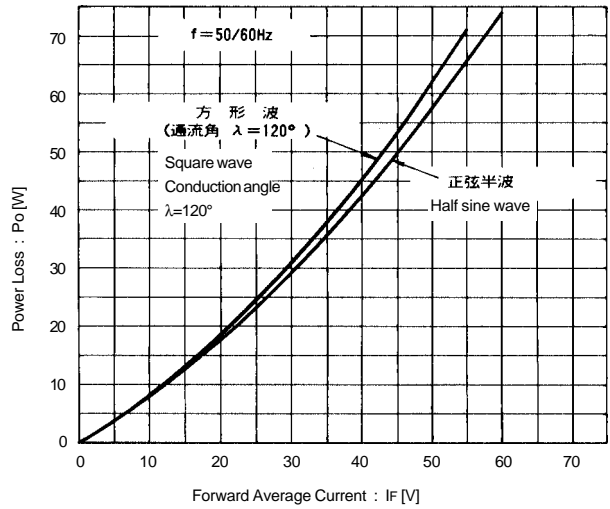

Forward Average Current vs. Case Temperature

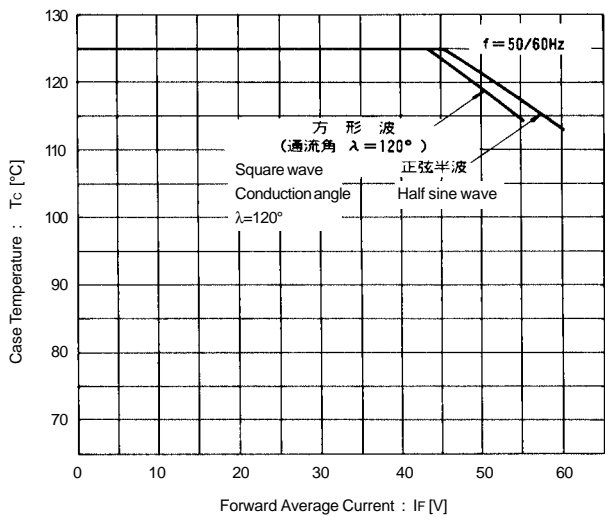

Surge Current

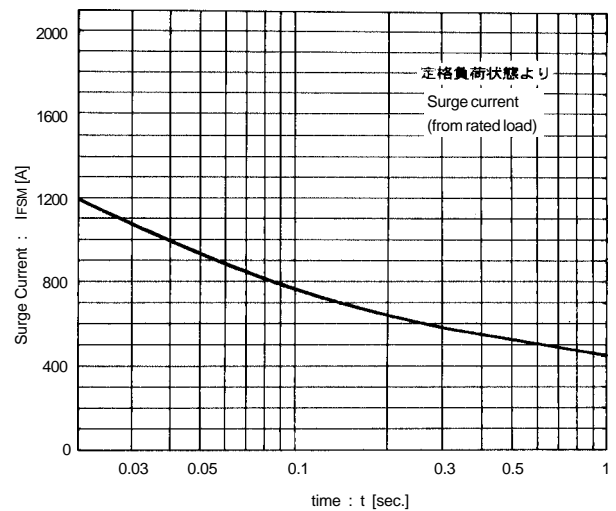

Transient Thermal Impedance

