



www.kel-electronics.com
contact@kel-electronics.com

TIMER & VOLTAGE RELAY (TVR-16A)



Description

- Single phase motor protection
- Line monitoring for under voltage and overvoltage
- Adjustable time delay
- Wide voltage range and control

User interface

Rotate with a screwdriver each of these 3 parameters in order to setup your phase monitoring relay :

- Timer** : delay of time to wait after a safe voltage range
- Low V** : under this voltage edge the relay will drop out
- High V** : over this voltage edge the relay will drop out

The status of the LEDs is in this form :

- **On** : indicate normal conditions
- **Wait** : indicate that you are in the delay time waiting
- **Low** : indicate that the voltage is below the value set
- **High** : indicate that the voltage is above the value set

- N.B.** The **TVR-16A** type is with regular plug and regular socket
- The **TVR-SH** type is with shuko plug and shuko socket built-in
- The **TVR-110V** type is with different labeling for 110VAC power supply



Technical data

Power supply	90 ~ 270VAC (50/60Hz)
Control action	ON / OFF Type ; The output status are indicated with a bright LEDs
Control output available	Relay control with 1 changeover output contact : Max Switching Voltage : 440 VAC / 125 VDC Max Switching Current : 16 A for resistive load Max Switching Power : 3000VA / 1Hp
Timer range	Min 5 sec up to Max 10 min
Low voltage range	Min 165V up to Max 205V (Hysteresis 8V)
High voltage range	Min 220V up to Max 250V (Hysteresis 3V)
Accuracy	1% full scale
Ambient conditions	Indoor use only , 0 ~ 50°C (32 ~ 122°F); < 90% RH non-condensing
Power consumption	< 5VA
Dimensions	160 x 90 x 54 mm (6.3" H x 3.5" W x 2.1" D)
Housing & Enclosure	≈ 280g (0.61 lb.) ; Degree of protection : IP40 Flame retardant light-grey plastic

TIMER & VOLTAGE RELAY (TVR-60A)



Description

- Single phase motor protection
- Line monitoring for under voltage and overvoltage
- Adjustable time delay
- Wide voltage range and control
- High power switching capability

User interface

Rotate with a screwdriver each of these 3 parameters in order to setup your phase monitoring relay :

- Timer** : delay of time to wait after a safe voltage range
Low V : under this voltage edge the relay will drop out
High V : over this voltage edge the relay will drop out

The status of the LEDs is in this form :

- **On** : indicate normal conditions
- **Wait** : indicate that you are in the delay time waiting
- **Low** : indicate that the voltage is below the value set
- **High** : indicate that the voltage is above the value set



N.B. The **TVR-60A** type is with 16" built-in connector for input and output voltage
 The **TVR-20A** type is with 12" built-in connector for input and output voltage

Technical data

Power supply	90 ~ 270VAC (50/60Hz)
Control action	ON / OFF Type ; The output status are indicated with a bright LEDs
Control output available	Relay control with 1 changeover output contact : Max Switching Voltage : 270 VAC Max Switching Current : 60 A for resistive load Max Switching Power : 10000VA / 3Hp
Timer range	Min 5 sec up to Max 10 min
Low voltage range	Min 165V up to Max 205V (Hysteresis 8V)
High voltage range	Min 220V up to Max 250V (Hysteresis 3V)
Accuracy	1% full scale
Ambient conditions	Indoor use only , 0 ~ 50°C (32 ~ 122°F); < 90% RH non-condensing
Power consumption	< 5VA
Dimensions	160 x 90 x 54 mm (6.3" H x 3.5" W x 2.1" D)
Housing & Enclosure	≈ 340g (0.75 lb.); Degree of protection : IP40 Flame retardant light-grey plastic

DIGITAL TIMER & VOLTAGE RELAY (TVR-VM)



Description

- Single phase motor protection
- Line monitoring for under voltage and overvoltage
- True RMS voltage measurement
- Adjustable time delay by front keypad
- Wide voltage range and control
- Modular housing suitable for mounting on 35mm DIN rail (EN 50022)

User interface

- Press on the **Set** button to access the setup menu
Use the ▲ & ▼ buttons to scroll menu list :

H L T : High Limit Voltage
L L T : Low Limit Voltage
T d L : Time Delay On
E n d : Exit menu



To make an adjustment to one of these parameters :

- Press on the **Set** button in front of the displayed parameter
- Use the ▲ & ▼ buttons to make the adjustment
- Press again on the **Set** button to exit the selected parameter

The status of the LEDs is in this form :

- **On** : indicate normal conditions
- **Wait** : indicate that you are in the delay time waiting
- **Fault** : indicate that the voltage is below or above the values set

Technical data

Power supply	90 ~ 270VAC (50/60Hz)
Control action	ON / OFF type ; Based on Microchip PIC microcontroller Voltage is indicated on a 7segment display (1/25") in V The output status is indicated with bright LEDs
Control output available	Relay control with 1 (standard) or 2 changeover output contacts : Max Switching Voltage : 440 VAC / 125 VDC Max Switching Current : 16 A for resistive load Max Switching Power : 3000VA / 1Hp
Timer range	Min 0 sec up to Max 12.5 min
Low voltage range	Min 165V up to Max High Voltage -1 V (Hysteresis 8V)
High voltage range	Min Low Voltage +1 V up to Max 255V (Hysteresis 3V)
Accuracy	0.2% full scale ±1 digit
Ambient conditions	Indoor use only ; -30 ~70°C (-22 ~158°F); < 90% RH non-condensing
Power consumption	<5VA
Dimensions	90 x 54 x 58 mm (3.5" H x 2.1" W x 2.3" D)
Housing & Enclosure	≈ 125g (0.275 lb.) ; Degree of protection : IP40 Flame retardant plastic modular housing with transparent red snap-in cover, for mounting on 35mm DIN rail (EN 50022)

TIMER & VOLTAGE RELAY – 380V (MPS-380V)



Description

- Three phase motor protection
- Line monitoring for under voltage and overvoltage, for phase failure, phase sequence and asymmetry
- Adjustable time delay
- Wide voltage range and control
- Modular housing suitable for mounting on 35mm DIN rail (EN 50022)

User interface

Rotate with a screwdriver each of these 3 parameters in order to setup your phase monitoring relay :

- Timer** : delay of time to wait after a safe voltage range
- Low V** : under this voltage edge the relay will drop out
- High V** : over this voltage edge the relay will drop out



The status of the LEDs is in this form :

- **On** : indicate normal conditions
- **Wait** : indicate that you are in the delay time waiting
- **Rev.** : indicate that there is a phase reversal
- **Low** : indicate that the voltage is below the value set
- **High** : indicate that the voltage is above the value set

N.B. The relay will drop out 1second after **Low V** condition occurs

Technical data

Power supply	3 Phase 280 ~ 445VAC (50/60Hz)
Control action	ON / OFF type ; Based on Microchip PIC microcontroller The output status is indicated with bright LEDs
Control output available	Relay control with 2 changeover output contacts : Max switching voltage : 277 VAC / 30 VDC Max switching current : 10A for resistive load Max switching power : 2770VA / ½ Hp
Timer range	Min 1 sec up to Max 9 min
Low voltage range	Min 280V up to Max 370V
High voltage range	Min 385V up to Max 445V
Accuracy	1% full scale
Ambient conditions	Indoor use only , 0 ~ 50°C (32 ~ 122°F); < 90% RH non-condensing
Power consumption	<4VA
Dimensions	90 x 54 x 58 mm (3.5" H x 2.1" W x 2.3" D)
Housing & Enclosure	≈ 115g (0.25 lb.) ; Degree of protection : IP40 Flame retardant plastic modular housing with black snap-in cover, for mounting on 35mm DIN rail (EN 50022)

PHASE FAILURE & SEQUENCE RELAY (PFSR)



Description

- Three phase motor protection
- Monitoring for phase failure, under voltage, phase sequence and asymmetry
- For dual supply voltage either 380V or 190V
- Modular housing suitable for mounting on 35mm DIN rail (EN 50022)

User interface

Rotate with a screwdriver in order to setup your phase monitoring relay :

Potentiometer : power supply voltage of the 3 phase

The status of the LEDs is in this form :

- **On** : indicate normal conditions
- **Rev.** : indicate that there is a phase reversal
- **Fault** : indicate phase failure or asymmetry



Technical data

Power supply	For 190V: 3 Phase 170 ~ 250V AC (50/60 Hz) For 380V: 3 Phase 280 ~ 445V AC (50/60 Hz)
Control action	ON / OFF type ; The output status is indicated with bright LEDs
Control output available	Relay control with 2 changeover output contacts : Max switching voltage : 277 VAC / 30 VDC Max switching current : 10A for resistive load Max switching power : 2770VA / ½ Hp
Accuracy	1% full scale
Ambient conditions	Indoor use only ; -30 ~70°C (-22 ~158°F) ; < 90% RH non-condensing
Power consumption	< 4VA
Dimensions	90 x 36 x 58 mm (3.5" H x 1.4" W x 2.3" D)
Housing & Enclosure	≈ 115g (0.25 lb) ; Degree of protection : IP40 Flame retardant plastic modular housing with black snap-in cover, for mounting on 35mm DIN rail (EN 50022)

TIME RELAY - "ON DELAY" TIMER (TDL/M)



Description

- Timer relay with 220Vac power supply
- Adjustable time delay with a potentiometer
- Wide delay range up to 15 minutes
- Modular housing suitable for mounting on 35mm DIN rail (EN 50022)

User interface

Rotate with a screwdriver in order to setup your time delay for startup :

Delay : delay of time to wait after a startup power supply

The status of the LEDs is in this form :

- **Relay On** : indicate that the relay is energized under normal conditions
- **Time Delay** : indicate that you are in the delay time waiting

N.B. The **TDL-10A** type is with 10 amps switching capability
The **TDL-20A** type is with 20 amps switching capability

Technical data

Power supply	150 ~ 250VAC (50/60Hz)
Control action	ON / OFF type ; Based on Microchip PIC microcontroller The output status is indicated with bright LEDs
Control output available	Relay control with 2 changeover output contacts : Max switching voltage : 277 VAC / 30 VDC Max switching current : 10A for resistive load Max switching power : 2770VA / ½ Hp
Timer range	Min 3 sec up to Max 15 min
Accuracy	1% full scale
Ambient conditions	Indoor use only , 0 ~ 50°C (32 ~ 122°F); < 90% RH non-condensing
Power consumption	<4VA
Dimensions	90 x 36 x 58 mm (3.5" H x 1.4" W x 2.3" D)
Housing & Enclosure	≈ 105g (0.225 lb.) ; Degree of protection : IP40 Flame retardant plastic modular housing with black snap-in cover, for mounting on 35mm DIN rail (EN 50022)



DIGITAL TIMER RELAY (DTR-S)



Description

- Timer relay with 220Vac power supply
- Period and pulse duration modulation
- Wide period range up to 15 hours
- Adjustable period time by front keypad
- Modular housing suitable for mounting on 35mm DIN rail (EN 50022)

User interface

- Press on the **Set** button to access the setup menu
- Use the ▲ & ▼ buttons to scroll menu list :

T O n : Time On Relay (1 – 900)
T O F : Time Off Relay (1 – 900)
T Y P : Type **S E C** : seconds or **M i n** : minutes
E n d : exit menu

To make an adjustment to one of these parameters :

- Press on the **Set** button in front of the displayed parameter
- Use the ▲ & ▼ buttons to make the adjustment
- Press again on the **Set** button to exit the selected parameter

To restart the counter press on the ▲&▼ buttons simultaneously for 5 seconds

The status of the LEDs is in this form :

- **ON** : indicate that you are in the **Time On** period set (Relay energized)
- **OFF** : indicate that you are in the **Time Off** period set (Relay relieved)

Technical data

Power supply	90 ~ 270VAC (50/60Hz)
Control action	ON / OFF type ; Based on Microchip PIC microcontroller Time is indicated on a 7segment display (1/25") in V The output status is indicated with bright red LEDs
Control output available	Relay control with 1 (standard) or 2 changeover output contacts : Max switching voltage : 277 VAC / 30 VDC Max switching current : 10A for resistive load Max switching power : 2770VA / ½ Hp
Timer range	Min 1 sec up to Max 900 min (15 Hours)
Accuracy	0.5% full scale ±1 digit
Ambient conditions	Indoor use only ; -30 ~70°C (-22 ~158°F); < 90% RH non-condensing
Power consumption	<5VA
Dimensions	90 x 54 x 58 mm (3.5" H x 2.1" W x 2.3" D)
Housing & Enclosure	≈ 125g (0.275 lb.) ; Degree of protection : IP40 Flame retardant plastic modular housing with transparent red snap-in cover, for mounting on 35mm DIN rail (EN 50022)

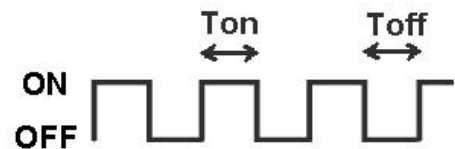

LIGHT SWITCH TIMER – MINUTERIE (LST-20A)



Description

- Timer for stairs lights (minuterie)
- Line output range up to 25Amps
- Adjustable time delay with a potentiometer
- Modular housing suitable for mounting on 35mm DIN rail (EN 50022)

User interface

Rotate with a screwdriver in order to setup your time delay :

Timer : delay of time for lighted lamps in minutes

The status of the LEDs is in this form :

- **On** : indicate that you are in the delay time waiting
- **OFF** : indicate that you are in the rest time



Installation

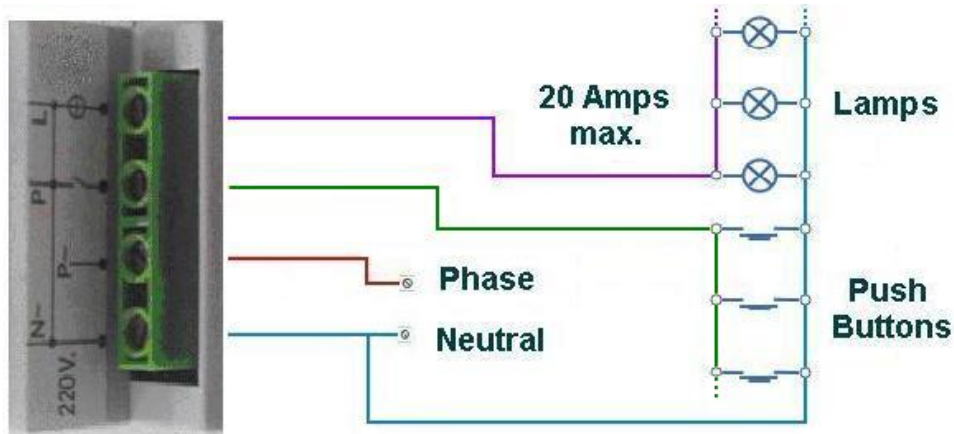

Technical data

Power supply	150 ~ 250VAC (50/60Hz)
Control action	ON / OFF type ; Based on Microchip PIC microcontroller The output status is indicated with bright LEDs
Control output available	Relay control with 1 changeover output contact : Max switching voltage : 277 VAC / 30 VDC Max switching current : 20A for resistive load Max switching power : 4400VA / 2 Hp
Timer range	Min 1 min up to Max 5 min
Accuracy	1% full scale
Ambient conditions	Indoor use only , 0 ~ 50°C (32 ~ 122°F); < 90% RH non-condensing
Power consumption	<5VA
Dimensions	90 x 54 x 58 mm (3.5" H x 2.1" W x 2.3" D)
Housing & Enclosure	≈ 125g (0.275 lb.) ; Degree of protection : IP40 Flame retardant plastic modular housing with black snap-in cover, for mounting on 35mm DIN rail (EN 50022)

VOLTMETER (VTM)



Description

- AC sine wave voltage reader
- True RMS voltage measurement
- Wide voltage range up to 500V line to line
- No need for range selection
- Used for single phase and three phase
- The input signal terminals are isolated from the input power supply terminals
- Modular housing suitable for mounting on 35mm DIN rail (EN 50022)

User interface

Connect this meter with a 220VAC power supply, and for the input signal you can connect any AC sine wave voltage :

- Between Line and Neutral (L - N)
- Between Line and Line (L - L)



Technical data

Power supply	150 ~ 250VAC (50/60Hz)
Display	Based on Microchip PIC microcontroller Voltage is indicated on a 7segment dual display (1/25") in °C
Display range	Min 0V up to Max 500V (L - L) or (L - N)
Accuracy	0.5% full scale ± 1 digit
Ambient conditions	Indoor use only ; -30 ~70°C (-22 ~158°F) ; < 90% RH non-condensing
Power consumption	< 3VA
Dimensions	90 x 36 x 58 mm (3.5" H x 1.4" W x 2.3" D)
Housing & Enclosure	\approx 95g (0.2 lb.) ; Degree of protection : IP40 Flame retardant plastic modular housing with transparent red snap-in cover, for mounting on 35mm DIN rail (EN 50022)

AMMETER (AMM)



Description

- AC sine wave current reader
- True RMS current measurement
- Push button to set current transformer ratio
- Wide current range and CT selection
- The input signal at current transformer terminals is isolated from the input power supply terminals
- Modular housing suitable for mounting on 35mm DIN rail (EN 50022)

User interface

Connect this meter with a 220VAC power supply

To set the Current Transformer (CT) value based to 5A input ratio:

- Press and hold for 3 seconds on the **Set** button to access the setup menu
- The display will indicate the CT value to be set
- Press once a time on the **Set** button to scroll throw available CT values
- Press and hold for 3 seconds on the **Set** button in front of the appropriate CT value to exit setup and save the new value
- The display will indicate now the exact current passing throw the input signal terminals

Technical data

Power supply	150 ~ 250VAC (50/60Hz)
Display	Based on Microchip PIC microcontroller Current is indicated on a 7segment dual display (1/25") in °C
Display range	Min 0A up to Max 999A
Accuracy	0.5% full scale ±1 digit
Ambient conditions	Indoor use only ; -30 ~70°C (-22 ~158°F) ; < 90% RH non-condensing
Power consumption	< 3VA
Dimensions	90 x 36 x 58 mm (3.5" H x 1.4" W x 2.3" D)
Housing & Enclosure	≈ 95g (0.2 lb.) ; Degree of protection : IP40 Flame retardant plastic modular housing with transparent red snap-in cover, for mounting on 35mm DIN rail (EN 50022)



THERMOMETER (THM)



Description

- Temperature reader
- Wide temperature range
- 2 wires NTC temperature sensor
- Modular housing suitable for mounting on 35mm DIN rail (EN 50022)

User interface

Connect this meter with a 220VAC power supply, and put your sensor anywhere you want to read the temperature in °C on its display.

To read the temperature of liquids, use a sensor holder made from copper or stainless steel to put the sensor inside and close it with silicon.

In case of prolongation of the sensor wires or sent with power cables and high frequency ones, it is preferred to use a shielded cable for the sensor.

- **H I** : Temperature higher then 99°C
- **L O** : Temperature lower then -30°C
- **S C** : Short circuit connection
- **O C** : Open circuit connection



Technical data

Power supply	150 ~ 250VAC (50/60Hz)
Display	Based on Microchip PIC microcontroller Temperature is indicated on a 7segment dual display (1/2") in °C
Display range	Min -9°C up to Max +99°C
Accuracy	0.5% full scale ±1 digit
Ambient conditions	Indoor use only ; -30 ~70°C (-22 ~158°F) ; < 90% RH non-condensing
Power consumption	< 3VA
Dimensions	90 x 36 x 58 mm (3.5" H x 1.4" W x 2.3" D)
Housing & Enclosure	≈ 95g (0.2 lb.) ; Degree of protection : IP40 Flame retardant plastic modular housing with transparent red snap-in cover, for mounting on 35mm DIN rail (EN 50022)
Sensors included	NTC thermistor ; 10 KΩ @ 25°C (77°F) ± 0.2°C 6.0 Ø x 50 L mm, stainless steel, 135°C max applicable temperature <u>N.B.</u> DO NOT MERGE THE SENSOR NAKED IN LIQUID

MANUAL THERMOCONTROL (THC/M)



Description

- Temperature reader and relay control
- Set point setting by front keypad
- For heating purpose with fixed hysteresis
- Wide temperature range and control
- Modular housing suitable for mounting on 35mm DIN rail (EN 50022)

User interface

- Press on the **Set** button to setup the controller, the setting led will turn on, the display will indicate the temperature to be set
- Use a screwdriver to rotate the axe to the desirable value, press on the **Set** button to release, the setting led will turn off and the display will indicate the sensor temperature
- Fixed parameters :
Hysteresis : 5 °C
Purpose : Heating
- **H I** : Temperature higher then 99 °C
- **L O** : Temperature lower then -30 °C
- **S C** : Short circuit connection
- **O C** : Open circuit connection



Technical data

Power supply	175 ~ 245VAC (50/60Hz)
Control action	ON / OFF type ; Based on Microchip PIC microcontroller Temperature is indicated on a 7segment 1/2" dual display in °C The output status is indicated with bright-red LEDs
Control output available	Relay control with 1 (standard) or 2 changeover output contacts : Max switching voltage : 277 VAC / 30 VDC Max switching current : 20A for resistive load Max switching power : 4400VA / 2 Hp
Display range	Min -9 °C up to Max +99 °C
Accuracy	0.5% full scale ±1 digit
Ambient conditions	Indoor use only ; -30 ~70 °C (-22 ~158 °F) ; < 90% RH non-condensing
Power consumption	< 6VA
Dimensions	90 x 54 x 58 mm (3.5" H x 2.1" W x 2.3" D)
Housing & Enclosure	≈ 235g (0.52 lb) ; Degree of protection : IP40 Flame retardant plastic modular housing with transparent red snap-in cover, for mounting on 35mm DIN rail (EN 50022)
Sensors included	NTC thermistor ; 10 KΩ @ 25 °C (77 °F) ± 0.2 °C 6.0 Ø x 50 L mm, stainless steel, 135 °C max applicable temperature <u>N.B.</u> DO NOT MERGE THE SENSOR NAKED IN LIQUID

SELECTABLE THERMOCONTROL (THC/S)



Description

- Temperature reader and relay control
- Set points settings by front keypad
- Adjustable hysteresis settings
- Wide temperature range and control
- Modular housing suitable for mounting on 35mm DIN rail (EN 50022)

User interface

- Press on the **Set** button to access the setup menu
Use the **▲** & **▼** buttons to scroll menu list :

S P : Set Point

H S : Hysteresis

T P : Type **H T** : Heating or **C L** : Cooling

E d : exit menu



To make an adjustment to one of these parameters :

- Press on the **Set** button in front of the displayed parameter
 - Use the **▲** & **▼** buttons to make the adjustment
 - Press again on the **Set** button to exit the selected parameter.
- Pressing on the **▲** buttons will show the high temperature set.
 - Pressing on the **▼** buttons will show the low temperature set.
 - **H I** : Temperature higher then 99°C **L O** : Temperature lower then -30°C
 - **S C** : Short circuit connection **O C** : Open circuit connection

Technical data

Power supply	175 ~ 245VAC (50/60Hz)
Control action	ON / OFF type ; Based on Microchip PIC microcontroller Temperature is indicated on a 7segment 1/2" dual display in °C The output status is indicated with bright-red LEDs
Control output available	Relay control with 1 (standard) or 2 changeover output contacts : Max switching voltage : 277 VAC / 30 VDC Max switching current : 20A for resistive load Max switching power : 4400VA / 2 Hp
Display range	Min -30°C up to Max +99°C
Accuracy	0.2% full scale ±1 digit
Ambient conditions	Indoor use only ; -30 ~70°C (-22 ~158°F) ; < 90% RH non-condensing
Power consumption	< 6VA
Dimensions	90 x 54 x 58 mm (3.5" H x 2.1" W x 2.3" D)
Housing & Enclosure	≈ 235g (0.52 lb) ; Degree of protection : IP40 Flame retardant plastic modular housing with transparent red snap-in cover, for mounting on 35mm DIN rail (EN 50022)
Sensors included	NTC thermistor ; 10 KΩ @ 25°C (77°F) ± 0.2°C 6.0 Ø x 50 L mm, stainless steel, 135°C max applicable temperature <u>N.B.</u> DO NOT MERGE THE SENSOR NAKED IN LIQUID

DIFFERENTIAL THERMOCONTROL - Δt (DTHC/M)



Description

- Temperature reader and differential thermocontrol
- Fixed temperature settings
- Wide temperature range
- Modular housing suitable for mounting on 35mm DIN rail (EN 50022)

User interface

- To read the upper sensor temperature :
press on the **Set** button,
the upper sensor led will turn on
- To read the lower sensor temperature :
press on the **Set** button to release,
the lower sensor led will turn on
- Fixed parameters :
Differential High : 10°C
Differential Low : 5°C
No Defrost



- **H I** : Temperature higher then 99°C
- **S U** : Upper sensor short circuit
- **S L** : Lower sensor short circuit
- **L O** : Temperature lower then -9°C
- **O U** : Upper sensor open circuit
- **O L** : Lower sensor open circuit

Technical data

Power supply	175 ~ 245VAC (50/60Hz)
Control action	ON / OFF type ; Based on Microchip PIC microcontroller Temperature is indicated on a 7segment 1/2" dual display in °C The output status is indicated with bright-red LEDs
Control output available	Relay control with 1 (standard) or 2 changeover output contacts : Max switching voltage : 277 VAC / 30 VDC Max switching current : 10A for resistive load Max switching power : 2770VA / ½ Hp
Display range	Min -9°C up to Max +99°C
Accuracy	0.5% full scale ±1 digit
Ambient conditions	Indoor use only ; -30 ~70°C (-22 ~158°F) ; < 90% RH non-condensing
Power consumption	< 6VA
Dimensions	90 x 54 x 58 mm (3.5" H x 2.1" W x 2.3" D)
Housing & Enclosure	≈ 235g (0.52 lb) ; Degree of protection : IP40 Flame retardant plastic modular housing with transparent red snap-in cover, for mounting on 35mm DIN rail (EN 50022)
Sensors included	NTC thermistor ; 10 KΩ @ 25°C (77°F) ± 0.2°C 6.0 Ø x 50 L mm, stainless steel, 135°C max applicable temperature N.B. DO NOT MERGE THE SENSOR NAKED IN LIQUID

DIFFERENTIAL THERMOCONTROL - Δt (DTHC/S)



Description

- Temperature reader and differential thermocontrol
- Adjustable temperature settings by front keypad
- Defrost mode to prevent freezing of solar panels
- Wide temperature range and control
- Modular housing suitable for mounting on 35mm DIN rail (EN 50022)

User interface

- Press on the **Set** button to access the setup menu
- Use the **▲** & **▼** buttons to scroll menu list :

- d H** : large difference between sensors
- d L** : small difference between sensors
- d F** : defrost mode (-10°C up to +10°C)
- E d** : exit menu

To make an adjustment to one of these parameters :

- Press on the **Set** button in front of the displayed parameter
- Use the **▲** & **▼** buttons to make the adjustment
- Press again on the **Set** button to exit the selected parameter
- **Defrost mode** : the relay will energize when the upper sensor reaches the temperature set in defrost with a hysteresis of 3°C
- To read the upper sensor temperature, press on the **▲** button
- **H I** : Temperature higher then 99°C
- **S U** : Upper sensor short circuit
- **S L** : Lower sensor short circuit
- **L O** : Temperature lower then -30°C
- **O U** : Upper sensor open circuit
- **O L** : Lower sensor open circuit



Technical data

Power supply	175 ~ 245VAC (50/60Hz)
Control action	ON / OFF type ; Based on Microchip PIC microcontroller Temperature is indicated on a 7segment 1/2" dual display in °C The output status is indicated with bright-red LEDs
Control output available	Relay control with 1 (standard) or 2 changeover output contacts : Max switching voltage : 277 VAC / 30 VDC Max switching current : 10A for resistive load Max switching power : 2770VA / ½ Hp
Display range	Min -30°C up to Max +99°C
Accuracy	0.2% full scale ±1 digit
Ambient conditions	Indoor use only ; -30 ~70°C (-22 ~158°F) ; < 90% RH non-condensing
Power consumption	< 6VA
Dimensions	90 x 54 x 58 mm (3.5" H x 2.1" W x 2.3" D)
Housing & Enclosure	≈ 235g (0.52 lb) ; Degree of protection : IP40 Flame retardant plastic modular housing with transparent red snap-in cover, for mounting on 35mm DIN rail (EN 50022)
Sensors included	NTC thermistor ; 10 KΩ @ 25°C (77°F) ± 0.2°C 6.0 Ø x 50 L mm, stainless steel, 135°C max applicable temperature N.B. DO NOT MERGE THE SENSOR NAKED IN LIQUID

LEVEL METER (SLM)



Description

- Level reader for any tank shape
- Digital monitoring with high accuracy
- Easy installation with adjustable height
- Safe to use in explosive environment
- Wide level range for any depth
- Level sensor compatible with most liquids
- Modular housing suitable for mounting on 35mm DIN rail (EN 50022)

User interface

To install the level sensor :

- Make a hole on the top of the tank with a diameter between 33 and 37 mm
- Insert the probe into the tank until it reaches the bottom
- Adjust the flange position and fix it on the top of the tank
- Connect the 2 sensor wires with the module
- Connect the module with 220VAC power supply

To set the **FULL** level (**N.B:** *The tank must be full of water*) :

- **Put a jumper on the sensor connector for 3 seconds**
- **The display will blink 99, then you remove the jumper**

The level sensor standard sizes : 1 meter, 1.25 meter, 1.5 meter, 1.75 meter, 2 meters and any else will be made on demand

In case the sensor wires are set up with high power cables or with high frequency lines or in highly parasite area, it is preferred to use a shielded cable for the sensor to prevent reading disturbance

- **S C** : Short circuit connection
- **O C** : Open circuit connection

Specifications

Power supply	150 ~ 250VAC (50/60Hz)
Display	Based on Microchip PIC microcontroller Level is indicated on a 7segment 1/2" dual display in %
Display range	Min 0 % up to Max 99 %
Accuracy	1 % full scale ± 1 digit
Ambient conditions	Indoor use only ; -30 ~70°C (-22 ~158°F) ; < 90% RH non-condensing
Power consumption	< 3VA
Dimensions	90 x 36 x 58 mm (3.5" H x 1.4" W x 2.3" D)
Package description	\approx 95g (0.2 lb.) ; Degree of protection : IP40 Flame retardant plastic modular housing with transparent red snap-in cover, for mounting on 35mm DIN rail (EN 50022)
Sensors included	Reed technology with excellent operating life with magnetic floater Material: PVC ; Set up method: Adjustable height 5 hole flange Size of the hole to be cut at the top of the tank: \varnothing 33 ~ 37 mm



LEVEL CONTROL (SLC)



Description

- Level reader and relay control
- Digital monitoring with high accuracy
- Easy installation with adjustable height
- Pump control up to 2Hp switching power
- Level sensor compatible with most liquids
- Safe to use in explosive environment

User interface

- Press on the **Set** button to access the setup menu
- Use the ▲ & ▼ buttons to scroll menu list :

H L : High Limit
L L : Low Limit
E d : exit menu

To make an adjustment to one of these parameters :

- Press on the **Set** button in front of the displayed parameter
- Use the ▲ & ▼ buttons to make the adjustment
- Press again on the **Set** button to exit the selected parameter
- Pressing on the ▲ buttons will show the high limit set
- Pressing on the ▼ buttons will show the low limit set
- **S C** : Short circuit connection
- **O C** : Open circuit connection

To set the **FULL** level (**N.B:** *The tank must be full of water*) :

- **Put a jumper on the sensor connector for 3 seconds**
- **The display will blink 99, then you remove the jumper**



Specifications

Power supply	175 ~ 245VAC (50/60Hz)
Control action	ON / OFF type ; Based on Microchip PIC microcontroller Level is indicated on a 7segment 1/2" dual display in % The output status is indicated with bright-red LEDs
Control output available	Relay control with 1 (standard) or 2 changeover output contacts : Max switching voltage : 277 VAC / 30 VDC Max switching current : 20A for resistive load Max switching power : 4400VA / 2 Hp
Display range	Min 0 % up to Max 99 %
Accuracy	1 % full scale ±1 digit
Ambient conditions	Indoor use only ; -30 ~70°C (-22 ~158°F) ; < 90% RH non-condensing
Power consumption	< 6VA
Dimensions	90 x 54 x 58 mm (3.5" H x 2.1" W x 2.3" D)
Package description	≈ 235g (0.52 lb) ; Degree of protection : IP40 Flame retardant plastic modular housing with transparent red snap-in cover, for mounting on 35mm DIN rail (EN 50022)
Sensors included	Reed technology with excellent operating life with magnetic floater Material: PVC ; Set up method: Adjustable height 5 hole flange Size of the hole to be cut at the top of the tank: Ø 33 ~ 37 mm Standard sizes: 1 meter, 1.25 meter, 1.5 meter, 1.75 meter, 2 meters

LIQUID VOLUMETER (DLV)



Description

- Volume reader and level controller
- Diesel counter and dissipation alarm
- Applicable to any tank type and shape
- LCD screen for monitoring and troubleshoot
- Applicable to any model of pressure sensor
- Adjustable volume settings by front keypad
- Applicable to all types of fluids and liquids
- Modular housing suitable for mounting on 35mm DIN rail (EN 50022)

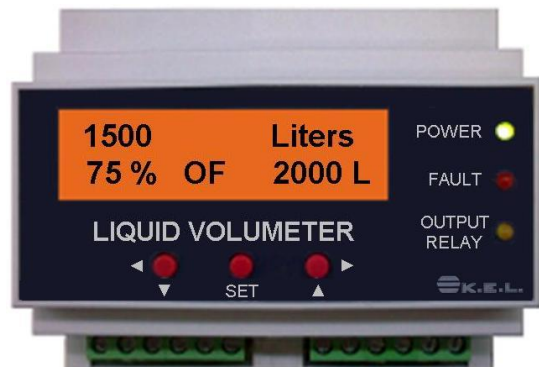

User interface

- Press on the **Set** button to access the setup menu
- Use the ▲ & ▼ buttons to scroll menu list :

Tank Shape	Tank Dimensions
Liquid Type	High Level Alarm
Output Relay	Low Level Alarm
Sensor Value	Diesel Counter

To make an adjustment to one of these parameters :

- Press on the **Set** button in front of the displayed parameter
- The letter “S” will appear on the left of the LCD
- Use the ▲ & ▼ buttons to make the adjustment
- Press again on the **Set** button to exit the selected parameter

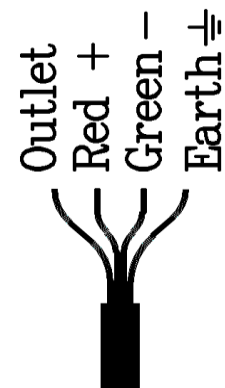

The status of the LEDs is in this form:

Power : to indicate normal power condition

Fault : to indicate any error in the system that will be messaged on the LCD for troubleshoot

Output Relay : to indicate the status of the output relay

Notice

- **Stable and accurate indication will be read after at least 1 minute of powered device.**
- **A minimum of 1 mm hole should exist at the top of the tank for air pressure release.**
- **In case of high liquid flow output as pumps and generators, it is preferable to use the submersible type of pressure sensor where the external sensor type is not applicable or should be installed in a separate tank output.**
- **It is preferable to extend the sensor cable with a shielded one to prevent parasite and noise disturbance.**
- **The external type sensor is preferable to be installed vertically.**
- **The external type sensor should not be installed right close to a valve set for the sensor only: the pass should contain a bypass circuit to prevent overpressure due to valve closing.**
- **The outlet tube at the end of the sensor cable should not be covered to prevent reading disturbance.**

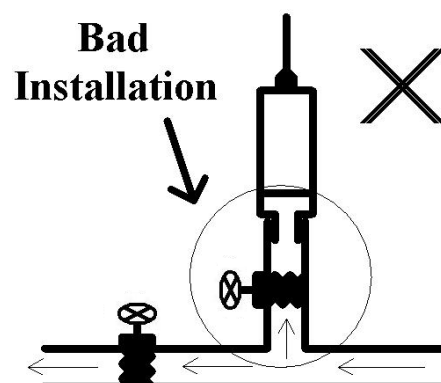

Technical data

Power supply	175 ~ 245 VAC (50/60 Hz)
Control action	Volume is indicated on a colored LCD in Liters with a percentage of the level of the tank capacity. Each status is indicated with bright LEDs and every error will be messaged clearly on the LCD for troubleshooting. A warning of overconsumption when it exceeds 1Liter /min continuously
Control output available	Relay control with 1 changeover output contact : Max switching voltage : 277 VAC / 30 VDC Max switching current : 10A for resistive load Max switching power : 2770VA / ½ Hp
Sensor value range	Min 0 bar up to Max 10 bar
Width & Length range	Min 0 meter up to Max 10 meters
Height range	Min 0 meter up to Max equivalent to sensor value and liquid type
Volume range	Min 0 liter up to Max 999,999 liters
Accuracy	0.5% Full Scale (Standard Permitted Error = 5 Liters / 1000)
Ambient conditions	Indoor use only , 0 ~ 50°C (32 ~ 122°F) , < 90% RH non-condensing
Power consumption	< 8VA
Dimensions	90 x 108 x 58 mm (3.5" H x 4.2" W x 2.3" L)
Housing & Enclosure	≈ 450g (1 lb.) ; Degree of protection : IP50 Flame retardant plastic modular housing with transparent snap-in cover, for mounting on 35mm DIN rail (EN 50022)
Sensors included available @ KEL	Pressure Sensor available : 0.2 bar ; 0.25 bar ; 0.6 bar 3 cm Diam. x 15 cm Length ; stainless steel ; ½ inch process connection N.B. THESE ARE NOT APPLICABLE TO GASOLINE OR KEROSENE

Rectangular

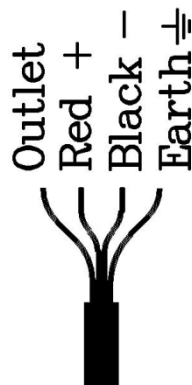
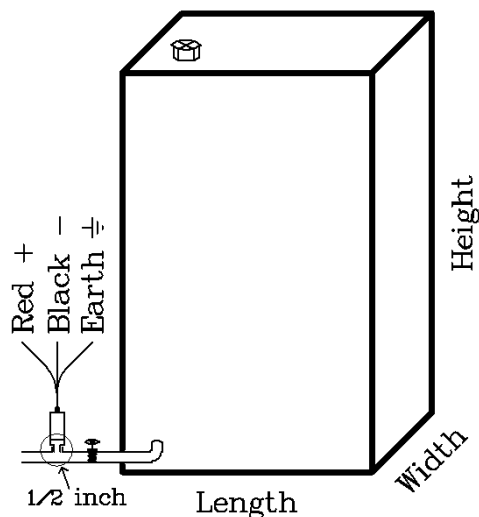

Circular

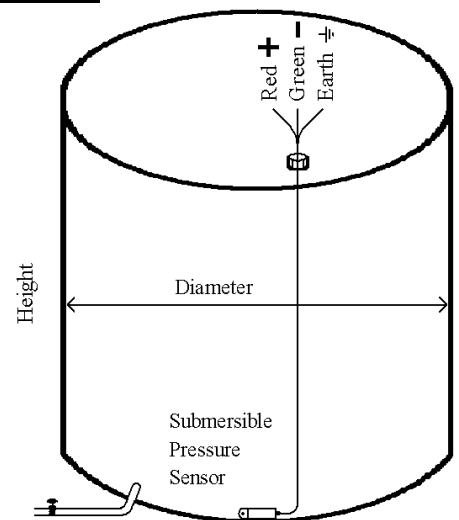

Cylindrical

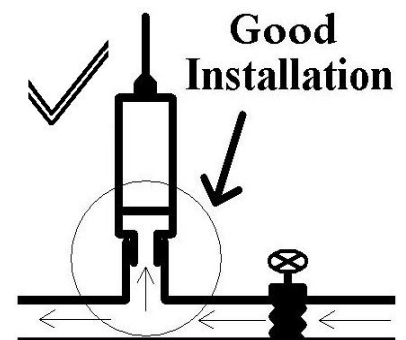
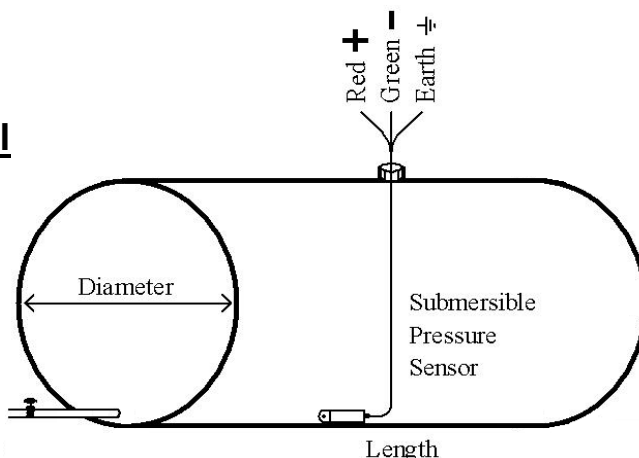

HEATING CONTROL SYSTEM (BTHC V2)



Description

- Temperature reader and relay control
- Timer (RTC) and Voltage Relay
- Alarm System for Safety
- Complete Control over Boiler Functionality
- LCD Screen and colored Status Indicators
- Set points Thermo control by front keypad
- Adjustable hysteresis settings
- Wide temperature range and control
- Analog Output 0 to 5 Vdc (optional)
- Modular housing suitable for mounting on 35mm DIN rail (EN 50022)



User interface

- Press on the **Set** button to access the setup menu
- Use the ▲ & ▼ buttons to scroll menu list
- To make an adjustment to one of these parameters:
- Press on the **Set** button in front of the displayed parameter
 - The letter “S” will appear on the left of the LCD
 - Use the ▲ & ▼ buttons to make the adjustment
 - Press again on the **Set** button to exit the selected parameter.

Technical data

Power supply	175 ~ 245Vac (50/60Hz)
Control action	Temperature is indicated on a colored LCD in Liters Each status (Timer, Voltage, Alarm, Error...) is indicated with a bright LED or with a message on the LCD
Control output available	Relay control with 2 changeover output contacts : Max switching voltage : 277 Vac / 30 Vdc Max switching current : 10A for resistive load Max switching power : 2770VA / ½ Hp
Display range	Min -30°C up to Max +120°C
Accuracy	0.2% full scale ±1 digit
Ambient conditions	Indoor use only ; -30 ~70°C (-22 ~158°F) ; < 90% RH non-condensing
Power consumption	< 10VA
Dimensions	90 x 108 x 58 mm (3.5" H x 4.2" W x 2.3" L)
Housing & Enclosure	≈ 450g (1 lb) ; Degree of protection : IP50 Flame retardant plastic modular housing with transparent snap-in cover, for mounting on 35mm DIN rail (EN 50022)
Sensors included	NTC thermistor ; 10 KΩ @ 25°C (77°F) ± 0.2°C 6.0 Ø x 50 L mm, stainless steel, 135°C max applicable temperature N.B. DO NOT MERGE THE SENSOR NAKED IN LIQUID