



N. MICRO

S.A.R.L.

Meeting & Serving the needs of OEMs in Lebanon & the region since 1996.

Introduction of our Company:

- *We are distributors of electronic components, power supply units, industrial & home automation, electrical panels, PV & UPS systems, batteries...*
- *We provide complete turnkey solutions and maintenance for Industrial automated control systems, Photovoltaic backup and remote power systems.*
- *We design, program and prototype electronic circuits*

Employees

- Our team consists of 12 employees:
- General Manager
- Sales Manager
- Two HR & Accounting
- Three Engineers
- Stock Manager
- Two drivers for deliveries
- One outside sales
- Two loaders

Our Branches



Beirut, Dora Branch



Zahle Beqaa Branch



Beirut Mar Michael Branch

SOME OF OUR BRANDS



- Power Supplies, Battery chargers, Backup systems
- LED Power supplies.



MICROCHIP

- Microcontrollers.

The logo for ema, featuring the letters 'ema' in a stylized yellow font with a registered trademark symbol.

- Industrial sensors and switches.



- Terminal blocks, connectors.

The logo for HONGFA, featuring the letters 'HF' in red inside a red circle, with 'HONGFA' in blue below it.

- Relays.



- Far Infrared Heaters



- Programmable Logic Controllers
- Variable frequency drives



- UPS backup systems
- Solar variable frequency drives



- Electronics development tools.



- Home Automation.



- Batteries.



High Reliability Standard Switching Power Supply

— one stop shopping for all the power you need —



LED Power Solution



Medical Power Solution



High Bay Lighting
Power Solution



LED Display Power
Solution



Green Energy Power
Solution



Burn-in Equipments
Power Solution



Drive Solutions

LSIS offers drive solutions that can achieve reduction in energy consumption significantly.



Low Voltage VFD



Medium Voltage VFD



Softstarter



PLC



Remote I/O



HMI



Servo Drive & Motor
(XGT Servo System)

new **LS IS**
Solar Pump Drive

Voc range : 240~800VDC

Power : 0.4~500kWp



Integrated MPPT (Maximum Power Point Tracking)

MPPT algorithm enables you to extract best power from your solar panel under all conditions. It tracks the maximum output power available from the solar panel during the day and automatically adjust them for the most optimal utilization of solar energy.

Answer for optimal off-grid solution

From irrigation of fields to remote villages or isolated places, solar pump system can be well suited to satisfy the water pumping demand. It is perfect and flexible option for power source.

Advanced time control

Scheduling (Time event: Real Time Clock) functionality makes possible for the solar drive system to star and stop automatically based on radiation condition of the sun.

All-round protection

Protection specified for pumps such as dry run, pipe broken, pump overload prevents any possible pump damages ensuring the system run safe and reliable.

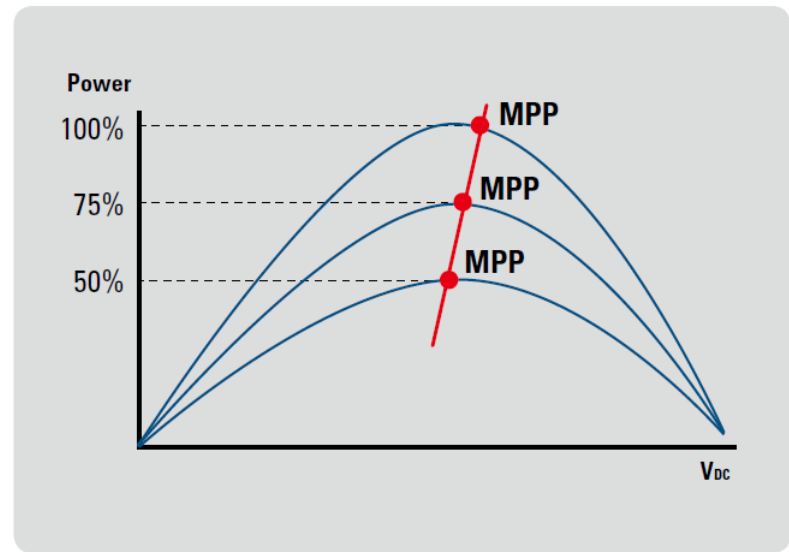

Solar water pump system

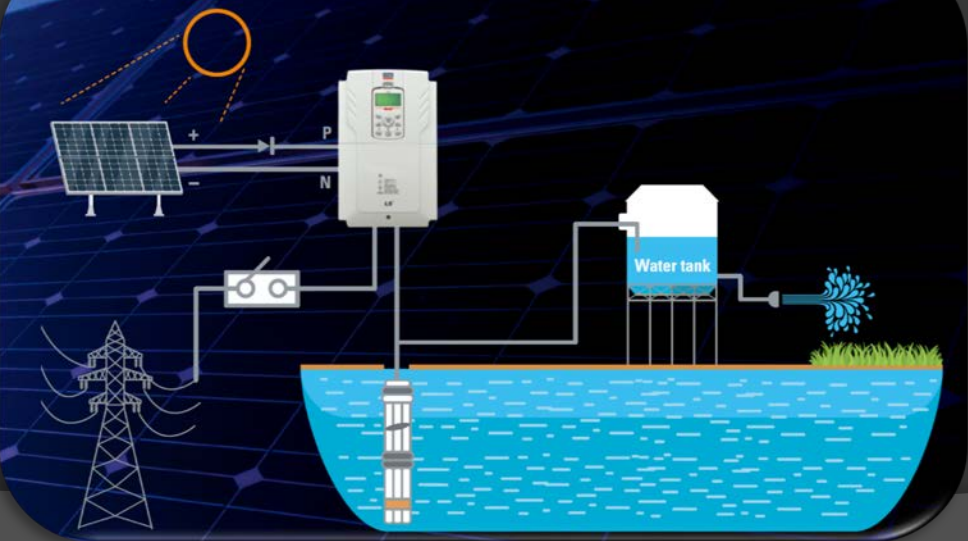

Let your Drive turn Light into Power!



Cost Saving

It immediately reduces or even eliminates the cost from electrical grid and protects your business against future power price rises.



Low Labor

Automatic control depending on solar energy availability enables unmanned control and requires little to no maintenance.



Eco Friendly

This renewable energy does not produce air pollutants without emitting CO₂.



Model name	NH-200 NH-200F	NH-290 NH-290F	NH-300 NH-300F	NH-600 NH-600F	NH-800 NH-800F
Fuel type	Diesel	Diesel	Diesel	Diesel	Diesel
Fuel Consumption L/h	0,9	1,2	1,4	1,7	2,3
Heat Output (kcal/h)	8,000kcal	11,000kcal	13,000kcal	16,000kcal	21,000kcal
Rated Voltage	AC220V/50Hz	AC220V/50Hz	AC220V/50Hz	AC220V/50Hz	AC220V/50Hz
Power Consumption	50W/90W	56W/96W	57W/97W	57W/97W	70W/110W
Dimensions (WxDxH)	760x320x930 (355)	760x320x1080 (355)	940x320x1080 (355)	1300x320x1100 (355)	1300x320x1270 (355)
Fuel tank capacity	25 ℓ	25 ℓ	30 ℓ	45 ℓ	45 ℓ
Exhaust diameter	Ø75mm	Ø75mm	Ø100mm	Ø100mm	Ø100mm
Weight	37kg/39kg	44kg/46kg	53kg/55kg	60kg/62kg	65kg/67kg

Basic Model

NH-200
NH-290
NH-300
NH-600
NH-800

With Fan Model

NH-200F
NH-290F
NH-300F
NH-600F
NH-800F

Professional Pumping Systems

DUKSHIN



MANUAL 	BATTERY 	DRUM 	CHEMICAL
ELECTRIC 12-24V DC	WATER 	ACCESSORIES 	OTHERS





MORE SECURE
MORE RELIABLE
MORE DURABLE

Relays

- Signal Relay
- Power Relay
- Latching Relay
- Automotive Relay
- Industrial Relay
- Relay Socket
- Hermetically Sealed Relay
- Relay Socket



DEGSON®

Terminal Blocks & Precise Moulds
ISO9001 ISO14001 ISO80079-34
UL US Ex CE ENEC CQC ROHS REACH

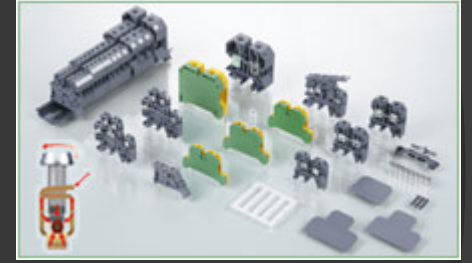
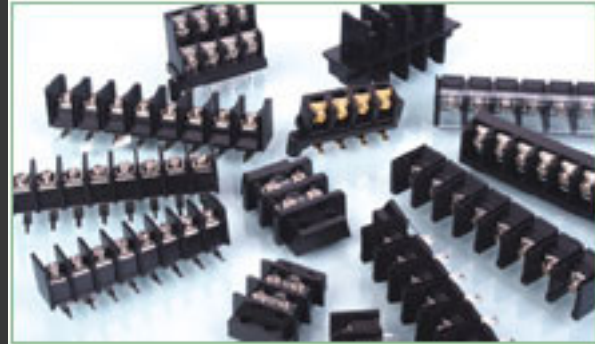
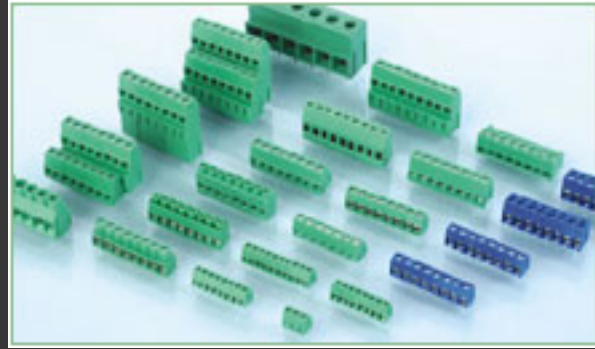

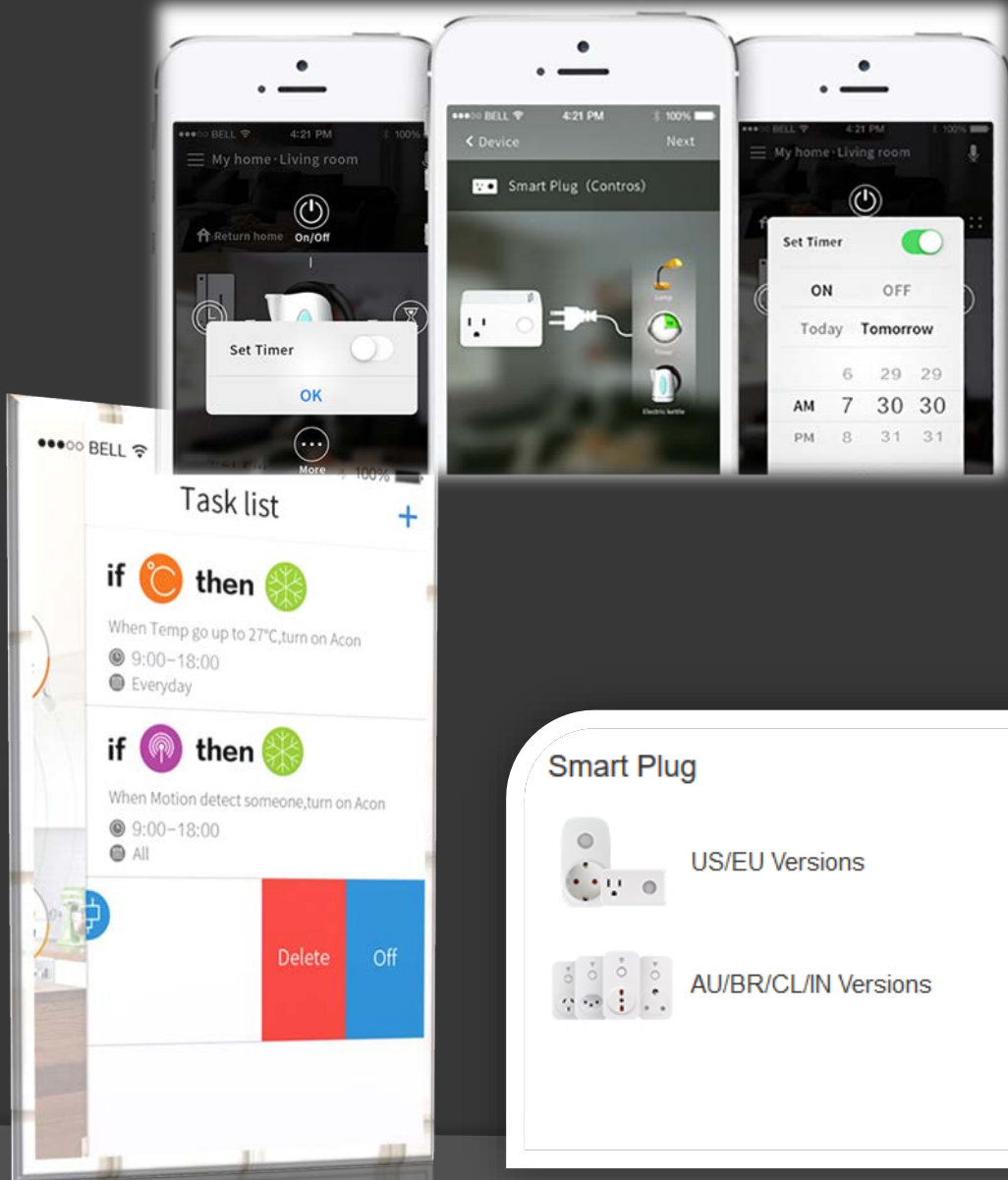

Smart Universal Remote Control

One button to control all appliances (TV, Air-conditioning, Motor Curtain, etc.)

Wi-Fi universal remote | RM Pro



Smart Plug



US/EU Versions



AU/BR/CL/IN Versions

Universal Remote



IR Control



IR+RF Control



RM pro 433MHz

Sensors



Alarm Kit



Environment Sensor

Light Switch



US/EU/UK Versions

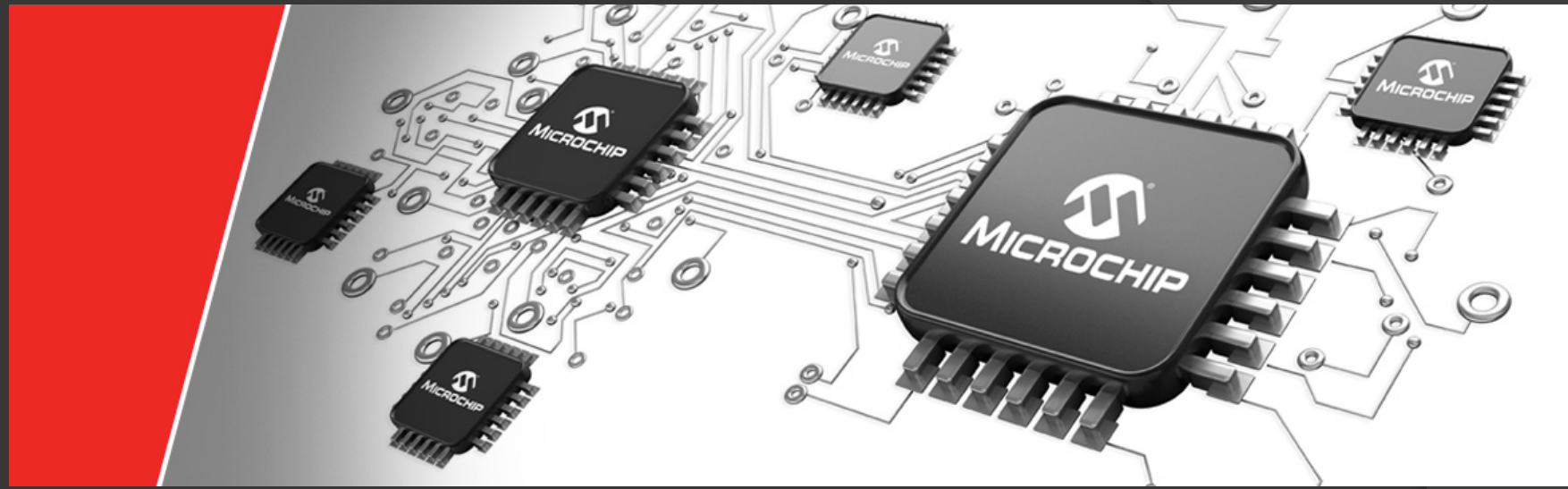

**Microchip microcontrollers,
development kits and peripheral ICs.**

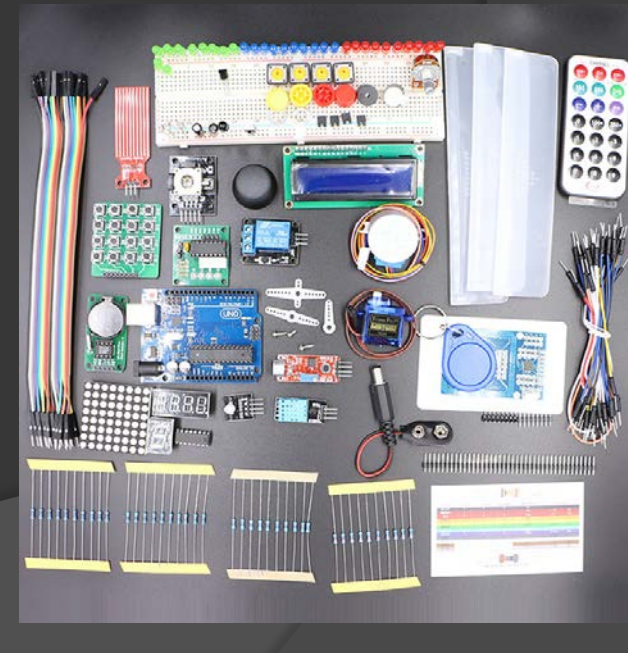
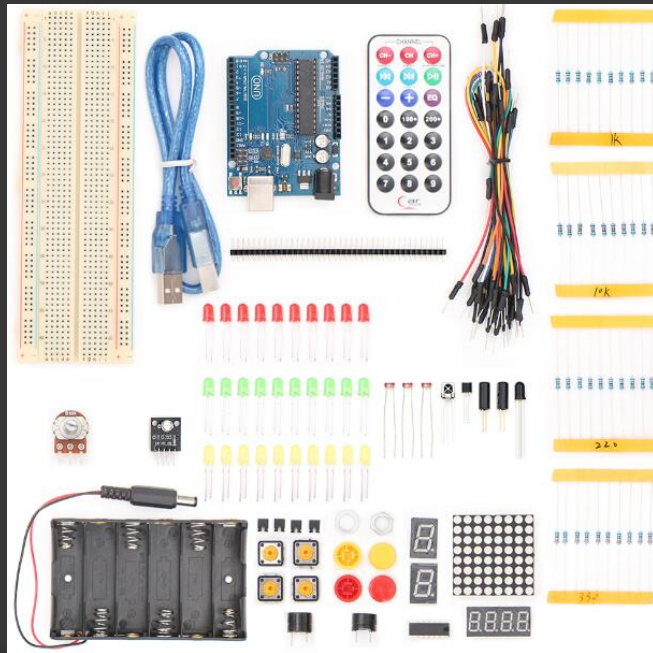
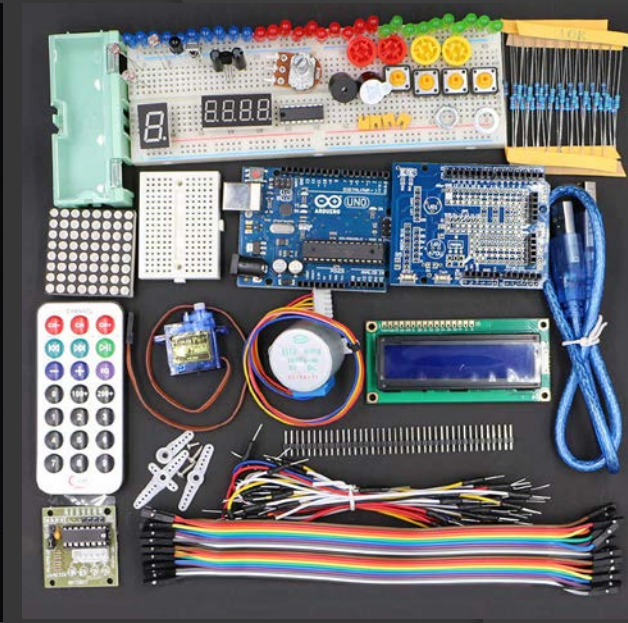
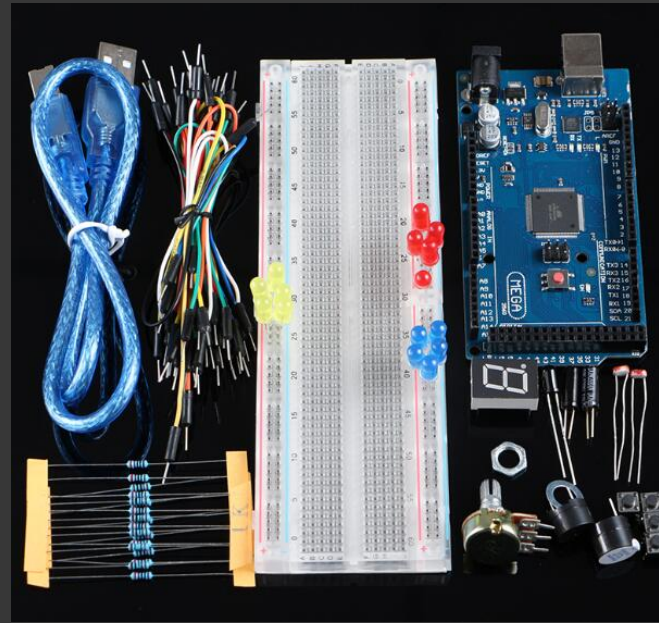
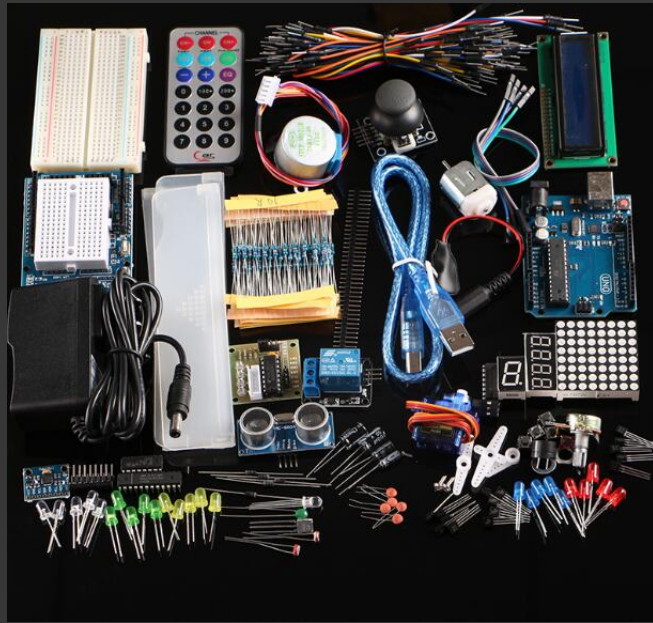

Online sinewave UPS

Internal battery & External battery long backup time models

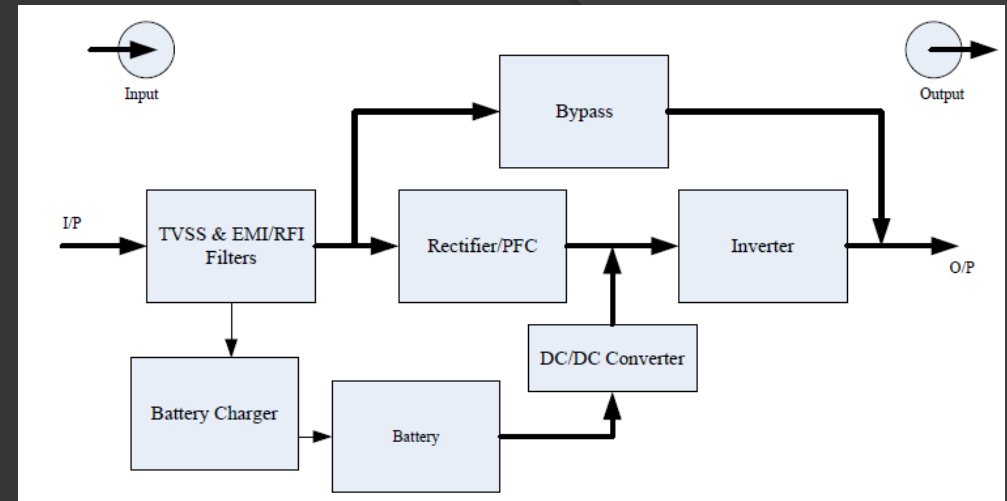

6 – 20KVA



1 – 3KVA



POWTRAN

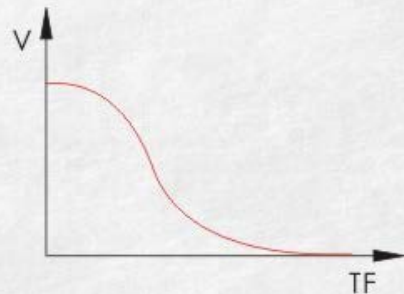

Soft stop function

Soft stop function efficiently solve the stop of inertial systems.

Surge problem: It can not be realized by traditional starting device.A



Multi-Mode Start

6 kinds of special start model: To suit complicated motor and load situation.

PR5200^{series}

High-quality Soft starter



PR5200 series soft starter, with the newest motor control theory and proprietary motor protection technology, it's an alternative products of old star delta conversion, auto-induction voltage-reduced starting and Excitation step-down device.

Braking resistors

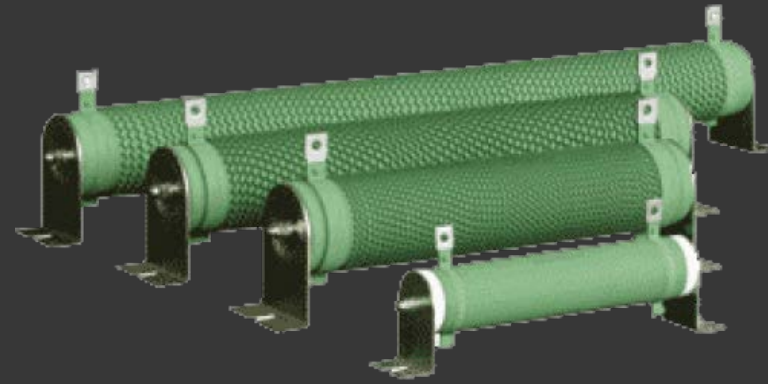

Solar Panels and accessories



Primary Batteries

maxell



Silver Oxide

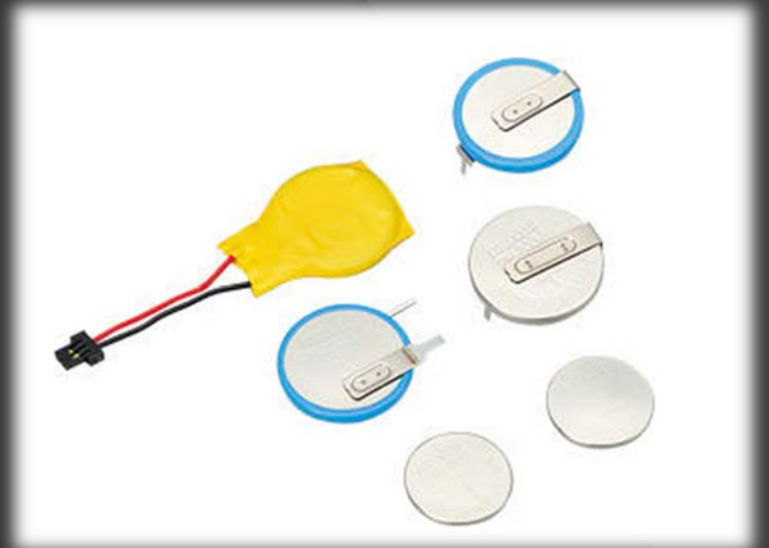

Lithium

GoldenPower®



Alkaline

EEMB®



Rechargeable Batteries



Flooded lead acid deep-cycle



Ni-MH Ni-Cd



Sealed lead acid deep-cycle



Li-ion
Li-Polymer

Panel Enclosures

B&J[®]



Switches

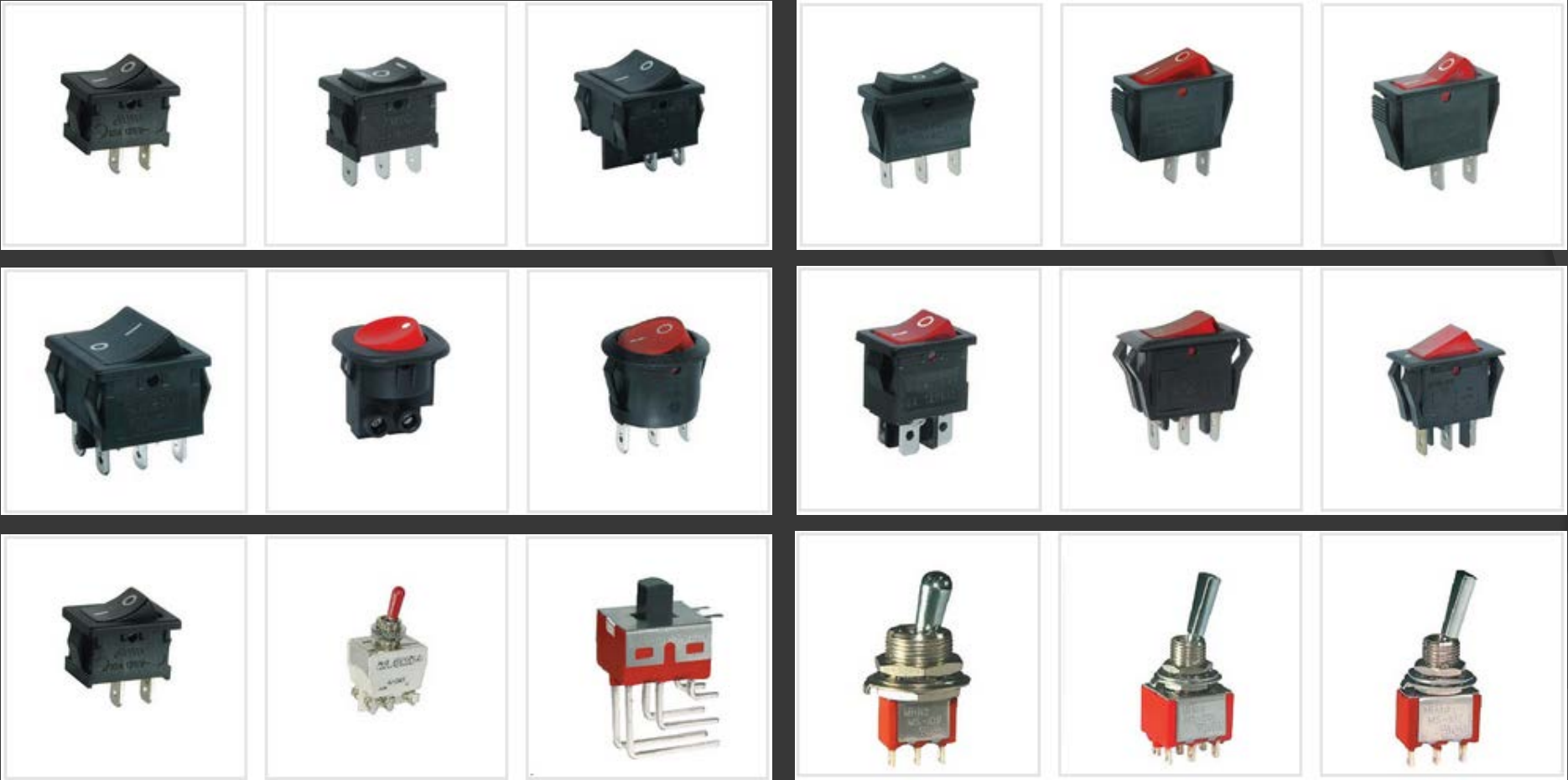

Diptronics

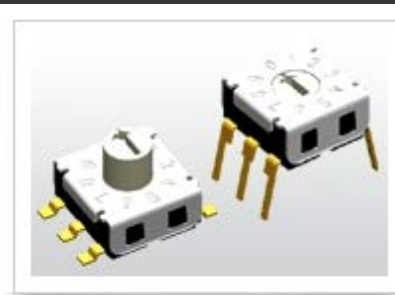
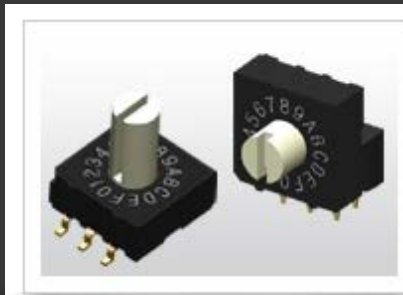
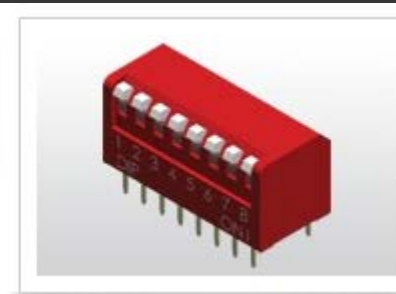
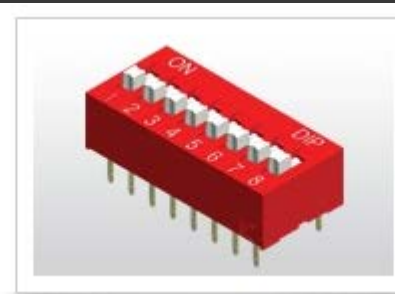
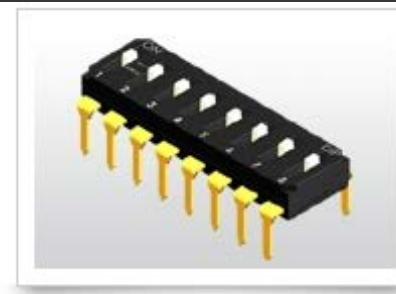
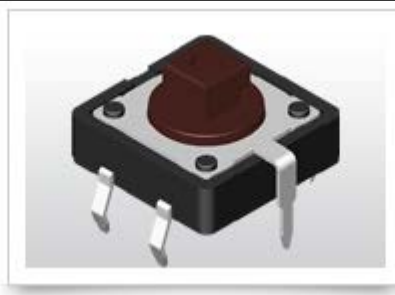

Universal Programmers



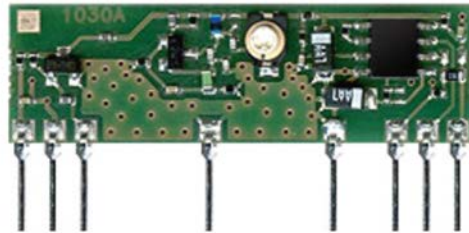

- ✓ Modulation: ASK (AM)
- ✓ Supply: 5V
- ✓ Frequency: 433.92 MHz
- ✓ Sensitivity: -106 dBm
- ✓ Consumption: 2.5 mA
- ✓ Dimension: 38.1 x 12.3 x 3 mm



- ✓ Modulation: ASK (AM)
- ✓ Supply: 3V
- ✓ Frequency: 433.92 MHz
- ✓ Sensitivity: -100 dBm
- ✓ Consumption: 0.07 mA
- ✓ Dimension: 40.1 x 17.5 x 5.5 mm

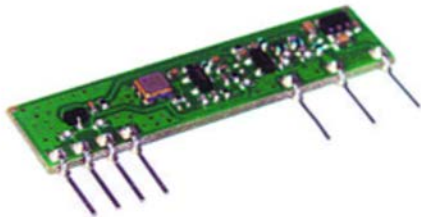

- ✓ Modulation: ASK (AM)
- ✓ Supply: 3 ÷ 12V
- ✓ Frequency: 433.92 MHz
- ✓ Consumption: 7.5 mA
- ✓ ERP Power: 10 mW
- ✓ Dimension: 38.1 x 11 x 3 mm



- ✓ Modulation: ASK (AM)
- ✓ Supply: 3V
- ✓ Frequency: 433.92 MHz
- ✓ Consumption: 25 mA
- ✓ ERP Power: 10 mW
- ✓ Dimension: 56 x 18.5 x 8 mm



- ✓ Modulation: FSK (FM) PLL
- ✓ Supply: 3V
- ✓ Frequency: 433.92 MHz
- ✓ Consumption: 14 mA
- ✓ ERP Power: 10 mW
- ✓ Dimension: 25.4 x 12.4 x 2.5 mm

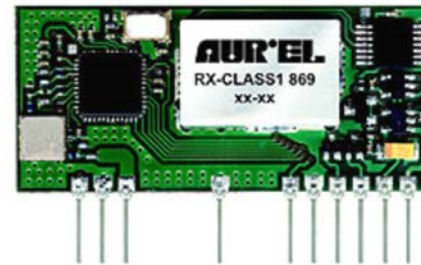

- ✓ Superheterodyne
- ✓ Modulation: FSK (FM)
- ✓ Supply: 3÷5.5 V
- ✓ Frequency: 869.2125 / 869.2375 MHz
- ✓ Sensitivity: -115 dBm
- ✓ Consumption: 40 mA
- ✓ Dimension: 45.7 x 20 x 3.5 mm

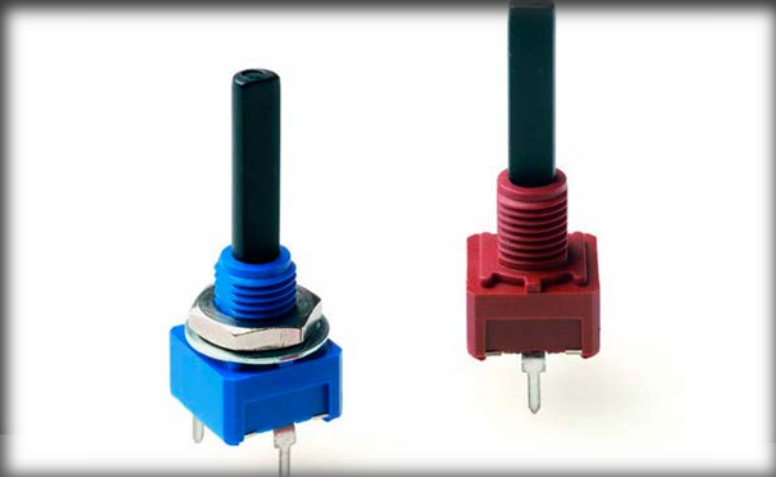
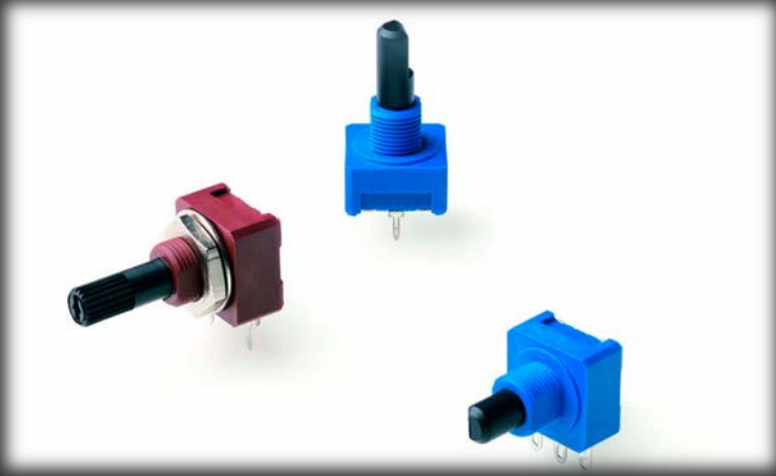
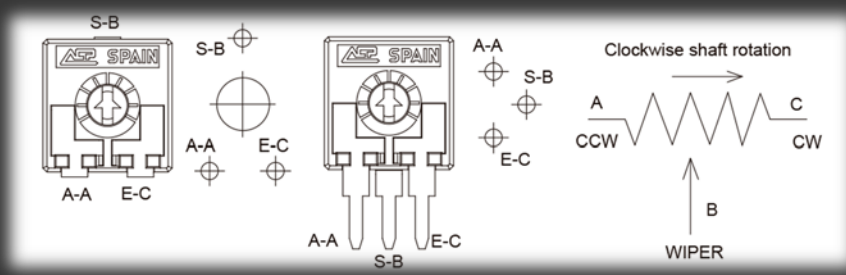

Programmable Relays





DC and AC Fans





杰美康机电
JUST MOTION CONTROL

Digital stepper driver and motor

Digital Driver with built-in micro technology, much improve smooth and noise from the low subdivision .

Integrating automatic parameter tuning function inside.

Can adjust the optimal operation parameters automatically for different motors to maximize the performance of the motor.





SHENMAO Technology Inc.

▪ SMT Assembly

- ☐ Tin Lead Solder Paste
- ☐ Lead-Free Solder Paste
- ☐ Water Soluble Solder Paste
- ☐ Package on Package Solder Paste
- ☐ Low Temperature Solder Paste
- ☐ Halogen Free Solder Paste
- ☐ Adhesive

▪ Wave Solder Assembly

- ☐ Solder Bar
- ☐ Cored Solder Wire
- ☐ Lead Free Solder Wire
- ☐ Halogens Free Solder Wire





Applications:

Monorail / Electric Chain Hoist:



SAGA1-L4



SAGA1-L6



SAGA1-L8



SAGA1-L6B



SAGA1-L8B



SAGA1-L10,
L10-1

Tower Crane:



SAGA1-10,
L10-1



SAGA1-K1,K2



SAGA1-K3,K4



SAGA1-L12,
L12-1



SAGA1-L40

Overhead Crane:



SAGA1-L8B



SAGA1-L10,
L10-1



SAGA1-L12,
L12-1



SAGA1-K1,K2



SAGA1-K3,K4



SAGA1-L40

Tow Truck:



SAGA1-L4
(DC TYPE)



SAGA1-L6
(DC TYPE)



SAGA1-L8
(DC TYPE)



SAGA1-V6
(DC TYPE)

Concrete Mixer:



SAGA1-L4
(DC TYPE)



SAGA1-L6
(DC TYPE)



SAGA1-L8
(DC TYPE)



SAGA1-V6
(DC TYPE)

Lifting Equipment:



SAGA1-L4
(DC TYPE)



SAGA1-L6
(DC TYPE)



SAGA1-L8
(DC TYPE)



SAGA1-V6
(DC TYPE)



Flow Sensors



30/50/70mm Multi-Layer Light Tower



Pressure Sensors



Ultrasonic Level Transmitter Rotating Paddle Level Switches



Capacitive Proximity Sensors



22/25/30mm Control Switches



Vibrating Fork Level Switches





Add-On Boards

We have an arsenal of accessory boards for almost everything you need. If you have a development system, we provide the easiest way to expand it's functionality in many segments. Add wireless communication, real-time clocks, storage interface, displays, measurement sensors, audio signalization, and much more with our accessory boards. We offer Proto boards, IDC10 header compatible boards and Click Boards™ built for mikroBUS™ pinout standard.



Click Boards (257)

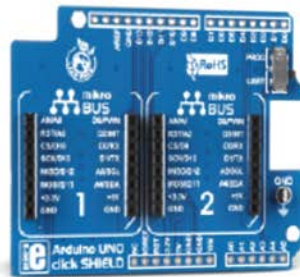

click shields (12)

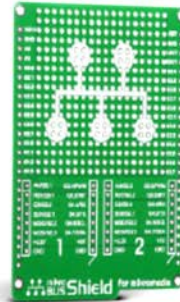

mikromedia shields (8)

wikromedia shields (8)

Some of our projects:



Cement Factory Control Panel & Automation with Billing & Remote Access

WEIGHING AND PACKING MACHINE CONTROL PANEL WIRING AND PLC PROGRAMMING



WEIGHING AND PACKING MACHINE:

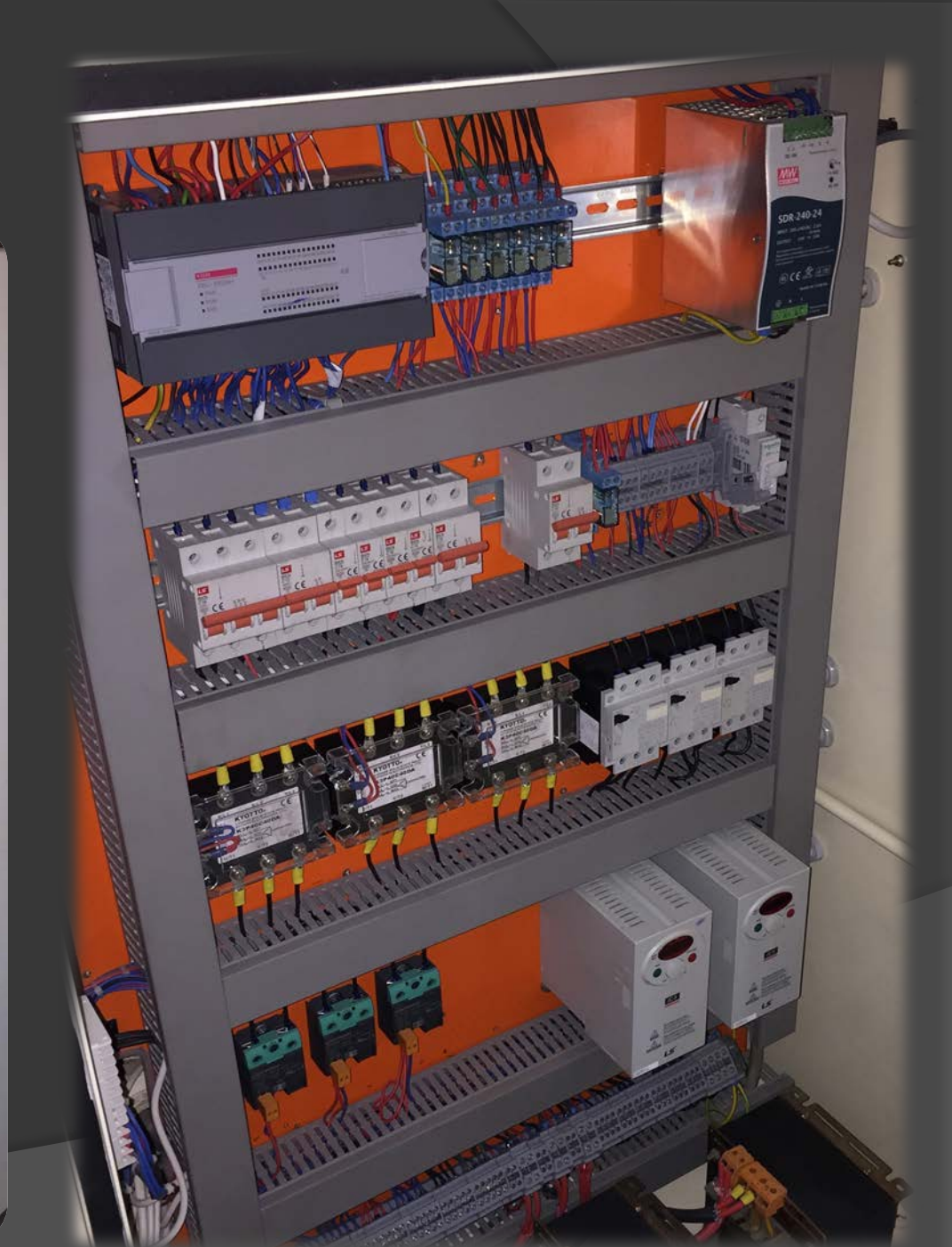
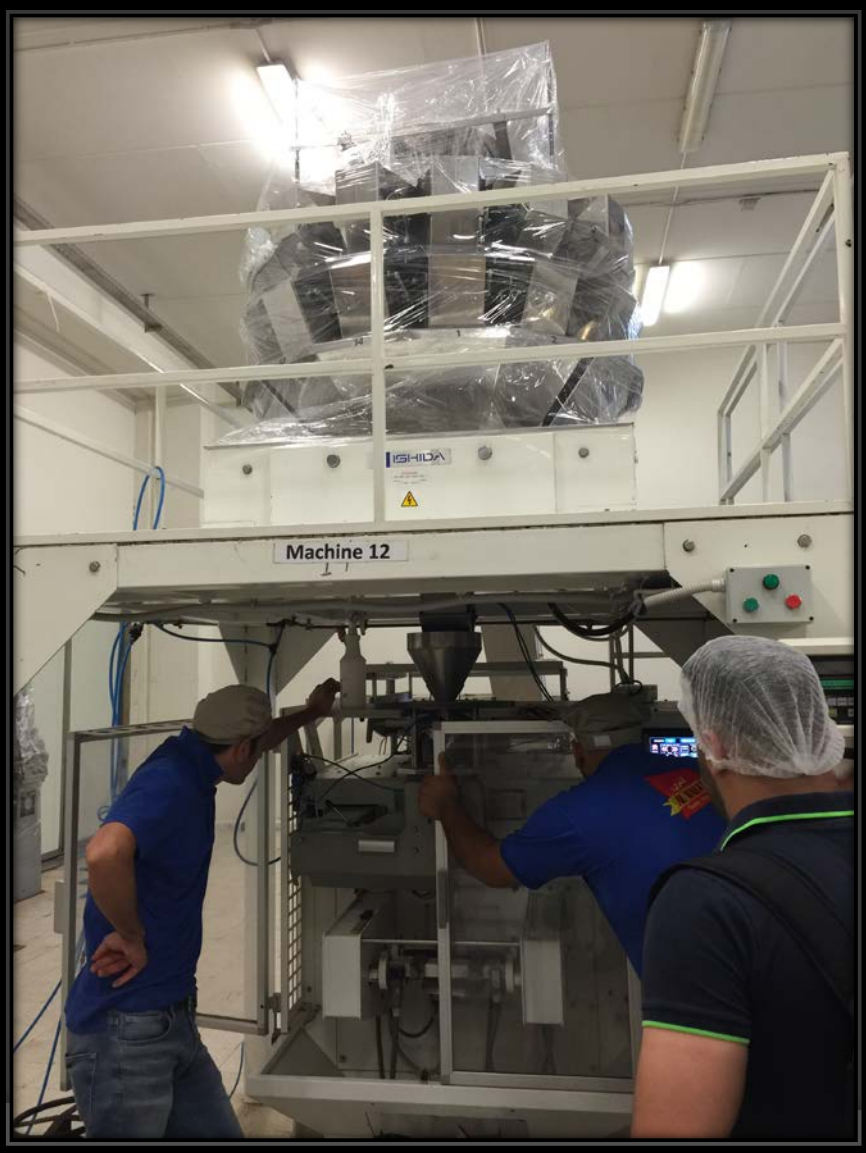

PLASTIC INJECTION MACHINE

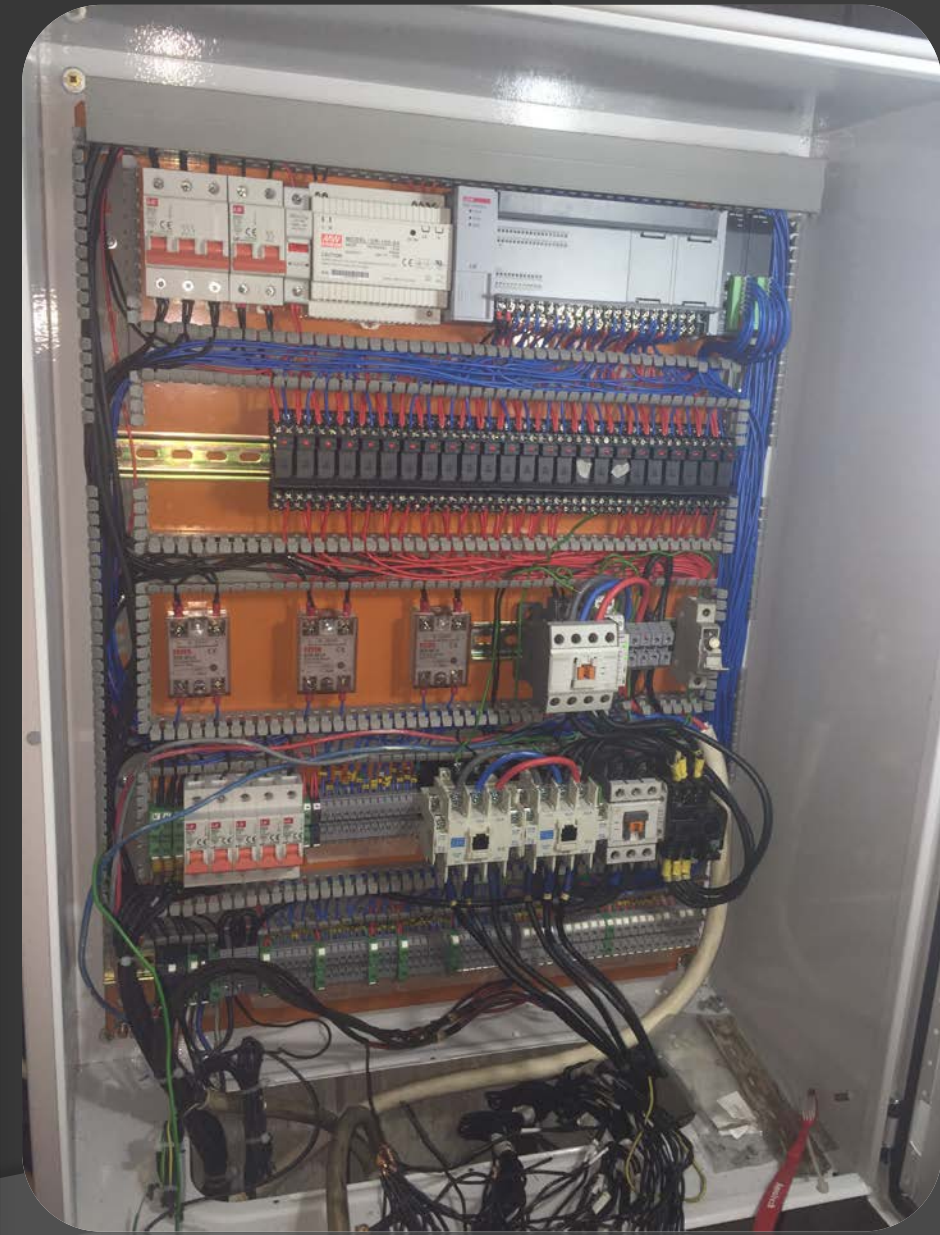

CONSTANT WATER PRESSURE CONTROL SYSTEM USING PLC & VFD



PID CONTROL



Our VFD units at Sicomo Paper recycling plant



Our VFD units at Pharmaline, Four 160kW Air Conditioning chiller compressors.

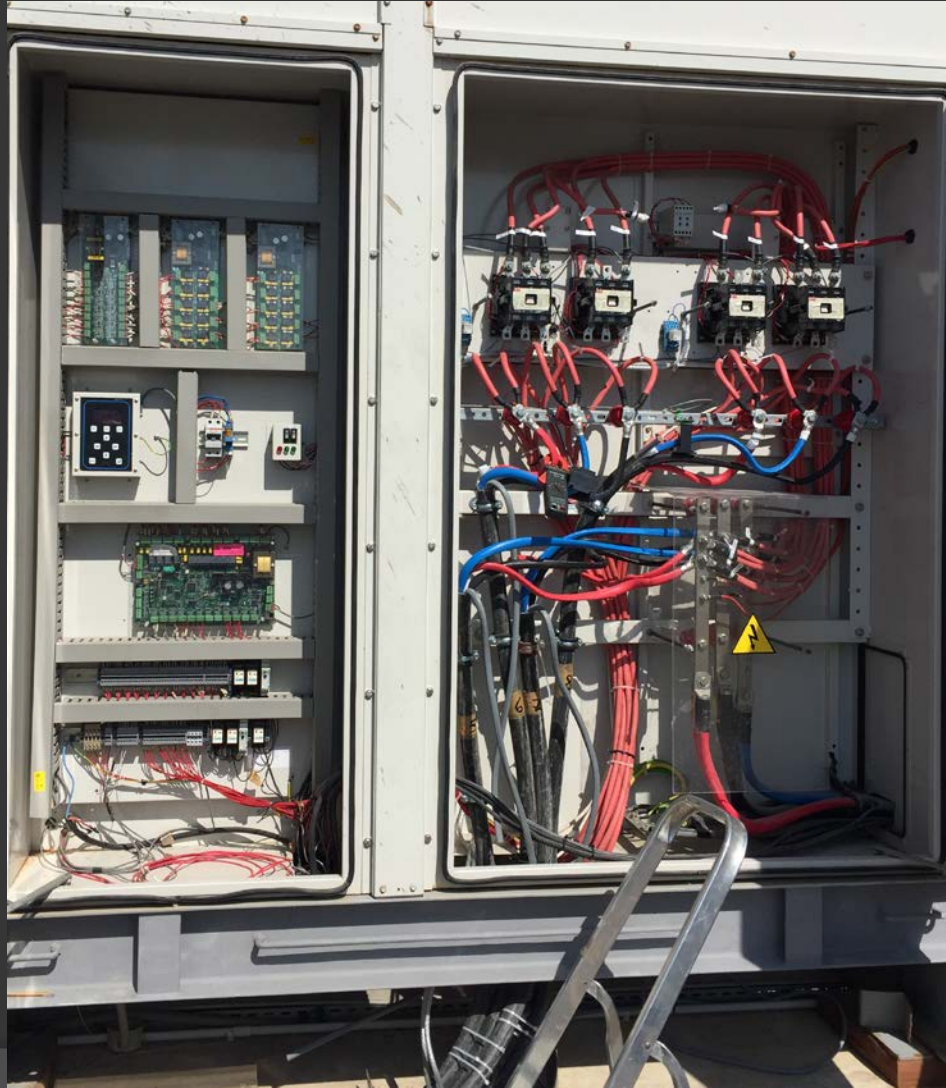

SOLAR WATER PUMPING 80HP

East Beqaa

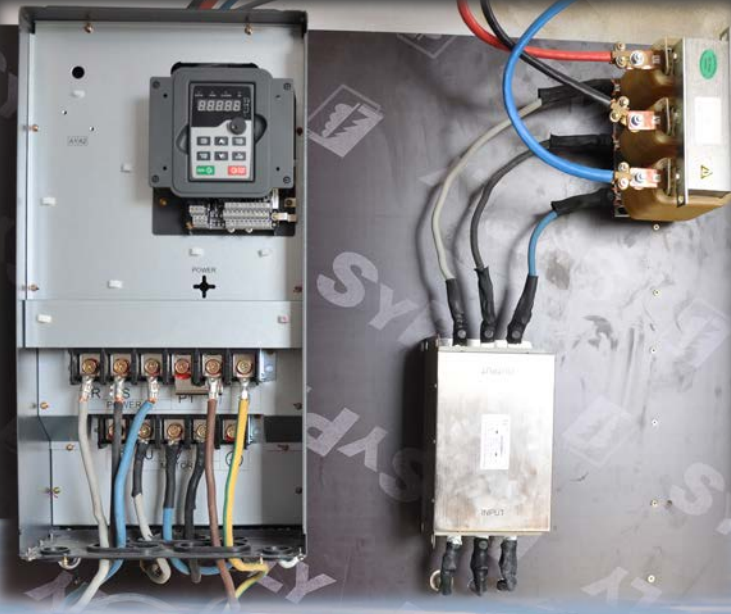

Solar VFD



100kW Array



Distribution

SOLAR TRACKING SYSTEM 3.6KW



Residential solar system with PV tracker



N. MICRO

S.A.R.L.

Meeting & Serving the needs of OEMs in Lebanon & the region since 1996.

Address #1

Dora Highway, Dedeyan Center,
Block A, Ground Floor,
Beirut, Lebanon
Tel: +961-1-260404
Fax: +961-1-260405

Email: info@narincomicro.com

Address #2

Zahle Industrial City,
Main Road - Naddaf Project No. 2
Tel: +961-70-687200
Tel: +961-8-931848

Address #3

Rmeil, Mar Mikhael,
Armenia Street,
Tel: +961-1-443560
Fax: +961-1-563720