



POWERBOX F

User Manual

Content

Statement of Law	1
Safety Precautions	2
Preface	3
1 Introduction	4
1.1 Brief Introduction	4
1.2 Product Properties	4
1.3 Product identity definition	5
2 Product Specification	6
2.1 Size and Weight	6
2.2 Performance Parameter	6
2.3 Interface Definition	6
2.4 Battery Management System(BMS)	8
2.4.1 Voltage Protection	8
2.4.2 Current Protection	9
2.4.3 Temperature Protection	9
2.4.4 Other Protection	9
3 Installation and Configuration	10
3.1 Preparations for installation	10
3.1.1 Environmental requirements.....	10
3.1.2 Tools and data	10
3.1.3 Technical preparation	11
3.1.4 Open the box to have inspection.....	11
3.1.5 Engineering coordination	13
3.2 Equipment installation	13
3.2.1 Floor installation	14
3.2.2 Mounted on the wall	15
3.2.3 Electrical installation.....	17
3.2.4 Battery module DIP switch definition and description.....	20
4 Use, maintenance and troubleshooting	25
4.1 Battery system usage and operation instructions	25
4.2 Alarm description and processing	26
4.2.1 Alarm and countermeasure influence system output.....	26
4.2.2 Alarm and countermeasure without affecting the output of the system	26
4.3 Analysis and treatment of common faults	27

Statement of Law

Copyright of this document belongs to Jiangsu Daqin New Energy Technology Co., Ltd.

No part of this documentation maybe excerpted, reproduced, translated, annotated or duplicated in any form or by any means without the prior written permission of Jiangsu Daqin New Energy Technology Co., Ltd. All Rights Reserved.

This product complies with the design requirements of environmental protection and personal safety. The storage, use and disposal of the products shall be carried out in accordance with the product manual, relevant contract or relevant laws and regulations.

Customer can check the related information on the website of Jiangsu Daqin New Energy Technology Co., Ltd when the product or technology is updated.

Please note that the product can be modified without prior notice.

Manual Version: V1.0

Manual NO.:

Revision History

Revision NO.	Revision Date	Revision Reason
1.0	2019.02.01	First Published

Safety Precautions



Warning

- Please do not put the battery into water or fire, in case of explosion or any other situation that might endanger your life.
- Please connect wires properly while installation, do not reverse connect. To avoid short circuit, please do not connect positive and negative poles with conductor (Wires for instance).
- Please do not stab, hit, trample or strike the battery in any other way.
- Please shut off the power completely when removing the device or reconnecting wires during the daily use or it could cause the danger of electric shock.
- Please use dry powder extinguisher to put out the flame when encountering a fire hazard, liquid extinguisher could result in the risk of secondary disaster.
- For your safety, please do not arbitrarily dismantle any component in any circumstances unless a specialist or an authorized one from our company, device breakdown due to improper operation will not be covered under warranty.



Caution

- We have strict inspection to ensure the quality when products are shipped out, however, please contact us if case bulging or another abnormal phenomenon.
- For your safety, device shall be ground connected properly before normal use.
- To assure the proper use please make sure parameters among the relevant device are compatible.
- **Please do not mixed-use batteries from different manufacturers, different types and models, as well as old and new together.**
- Ambient and storage method could impact the life span and product reliability, please consider the operation environment abundantly to make sure device works in proper condition.
- For long-term storage, the battery should be recharged once every 6 months, and the amount of electric charge shall exceed 80% of the rated capacity.
- Please charge the battery in 18 hours after it discharges fully and starts over-discharging protection.
Formula of theoretical standby time: $T=C/I$ (T is standby time, C is battery capacity, I is total current of all loads).
- The surface of the Powerbox cabinet is affixed with a torn invalid label. Therefore, before opening the cover to change the DIP switch mode, you need to contact DYNESS and inform the product ID. DYNESS will record this battery ID and authorize the opening operation to be performed. Except for changing the DIP switch mode, no other operations are allowed. In the next stage, you can log in to apply for operations directly on the DYNESS website.

Contact the authorized dealer or distributor of DYNESS for a new torn invalid sticker after tearing the original invalid label. When the operation is completed, paste the new one at a different position.

Preface

Manual declaration

POWERBOX F Lithium Iron Phosphate Battery is external battery module which can storage the power for home use. When the grid is on, it supplies the home loads and charges the battery meantime. When grid off, the battery discharges to power up the home loads.

POWERBOX F User manual systematically elaborates device structure, parameters, basic procedure and method of installation, operation, maintenance.

Safety Statement

- Only qualified trained professionals are allowed to install, operate, maintain the device.
- Please comply with local safety regulations and operational rules when installation, operation and maintenance, or it could lead to human injury or device damage.
- Mentioned attentions are only as a supplement to local safety regulations.
- The seller does not undertake any responsibility for device operations or usage violating general safety requirements and safety standards.

Sign explanation

Attention should be paid when configuring or operating POWERBOX-F series products, which follows below format to explain.



Caution

Neglecting the warnings might cause malfunction.

1 Introduction

1.1 Brief Introduction

POWERBOX F series lithium iron phosphate home battery is newly power storage products designed according to market demands, supplies reliable power for all kinds of home equipment. It is especially suitable for situations with higher temperatures, less space, higher demand of weight and life span.

POWERBOX F series lithium iron phosphate home battery carries self-developed battery management system. When the grid is on, it supplies the home loads and charges the battery meantime. When grid off, the battery discharges to power up the home loads. Batteries can be paralleled to build a module with more capacity to satisfy the longtime energy storage demand.

1.2 Product Properties

POWERBOX-F series energy storage product's anode materials are lithium iron phosphate, battery cells are managed effectively by BMS with better performance, the systems features as below:

- Comply with European ROHS, Certified SGS, employ non-toxic, non-pollution environment-friendly battery.
- Anode materials are lithium iron phosphate (LiFePO₄), safer with longer life span.
- Carries battery management system with better performance, possesses protection function like over-discharge, over-charge, over-current, abnormal temperature.
- Self-management on charging and discharging, Single core balancing function.
- Intelligent design configures integrated inspection module, with 3 remote functions (remote-measuring, remote-communicating and remote-controlling).
- Flexible configurations allow parallel of multi battery for longer standby time.
- Self-ventilation with lower system noise.
- Less battery self-discharge, then recharging period can be up to 10 months during the storage.
- No memory effect so that battery can be charged and discharged shallowly.
- With wide range of temperature for working environment, -20°C ~ +55 °C, circulation span and discharging performance are well under high temperature.
- Less volume, lighter weight, seal grade up to IP65 embedding design for easier installation and maintenance.

1.3 Product identity definition

FIG1-1 Battery Energy Storage System nameplate

DYNESS		RECHARGEABLE LI-ION BATTERY					
ENERGY STORAGE SYSTEM							
Type	<input type="checkbox"/> Powerbox F-2.5 <input type="checkbox"/> Powerbox F-5.0 <input type="checkbox"/> Powerbox F-7.5 <input type="checkbox"/> Powerbox F-10.0						
Nominal Energy	2.4kWh	4.8kWh	7.2kWh	9.6kWh			
Voltage Range	40.5V~54V	40.5V~54V	40.5V~54V	40.5V~54V			
Nominal Voltage	48V	48V	48V	48V			
Max.Charging Current	50A	100A	100A	100A			
Max.Discharging Current	50A	100A	100A	100A			
Ambient Temperature	-10℃~50℃	-10℃~50℃	-10℃~50℃	-10℃~50℃			
Protection Class	I	I	I	I			
IP Grade	IP65	IP65	IP65	IP65			
JIANGSU DAQIN NEW ENERGY TECH CO.,LTD. WWW.DYNESS.CN		MADE IN CHINA		S/N PBFS-			



Battery voltage is higher than safe voltage, direct contact with electric shock hazard.



Be careful with your actions and be aware of the dangers.



Read the user manual before using.



The scrapped battery cannot be put into the garbage can and must be professionally recycled.



After the battery life is terminated, the battery can continue to be used after it recycled by the professional recycling organization and do not discard it at will.



This battery product meets European directive requirements.



This battery product passed the TUV certification test.

2 Product Specification

2.1 Size and Weight

Table 2-1 POWERBOX F Series Device Model

Product Series	Specification Model	Nominal Voltage	Nominal Capacity	Dimension (mm)	Weight (kg)	IP Level
POWERBOX	POWERBOX F-10	48V	200Ah	928×555×210	113	IP65
POWERBOX	POWERBOX F-7.5	48V	150Ah	928×555×210	91	IP65
POWERBOX	POWERBOX F-5.0	48V	100Ah	928×555×210	69	IP65
POWERBOX	POWERBOX F-2.5	48V	50Ah	928×555×210	47	IP65

2.2 Performance Parameter

Table 2-2 POWERBOX F performance parameter

Item	POWERBOX F-2.5	POWERBOX F-5.0	POWERBOX F-7.5	POWERBOX F-10.0
Nominal Voltage(V)	48	48	48	48
Work Voltage Range(V)	42~54	42~54	42~54	42~54
Nominal Capacity(Ah)	50	100	150	200
Nominal Energy(kWh)	2.4	4.8	7.2	9.6
Nominal Power(kW)	0.7	1.5	2.2	2.9
Max Power(kW)	2.4	4.8	4.8	4.8
1S Peak Power(kW)	2.64	5.28	7.92	10.56
1S Peak Current(A)	55	110	165	220
Charging Current(A)	25	50	75	100
Discharge Current(A)	25	50	75	100

2.3 Interface Definition

This section elaborates on interface functions of the front panel of the device.

Figure2-1 POWERBOX F the sketch of front interface.



Table 2-3 Interface Definition

Item	Name	Definition
1	Positive socket	The battery DC output positive pole, which is connected to the positive pole of the inverter through the cable
2	COM	The CAN/RS485 socket is connected to the inverter CAN/RS485 interface through the communication cable. (Factory default CAN communication mode)
3	Negative socket	The battery DC output negative pole, which is connected to the negative pole of the inverter through the cable
4	LED1	Module 1 status indicator light
5	LED2	Module 2 status indicator light
6	LED3	Module 3 status indicator light
7	LED4	Module 4 status indicator light

Item	Name	Definition
8	Ground connection point	Shell ground connection
9	Reset switch	Press the switch and the battery system turn on. When the battery is in the nonuse state such as storage, transportation etc., it needs to be turn off by lpressing the Reset switch button, and the battery system will automatically sleep after the device without external load and power for 72 hours.
10	DC circuit breaker	Protective circuit

Table 2-4 LED status indicators (Take Powerbox F 10.0 as an example)

State	Protect/ Alarm/ Normal	Led1	Led2	Led3	Led4	Directions
Shut down		off	off	off	off	All off
Stand-by	Normal	●	●	●	●	Always on
	Alarm	●	●	●	●	Always on, Corresponding module capacity $5\% < SOC \leq 10\%$
	Protection	●	●	●	●	Flashing, (Corresponding module capacity, $0\% \leq SOC \leq 5\%$ /Low voltage alarm / Over-discharge protection / Over-charge protection / Over-current alarm or protection / Hardware failure / Temperature abnormality, etc.)
Charging/disc charging	Normal	●	●	●	●	Always on
	Alarm	●	●	●	●	Always on, Corresponding module capacity $5\% < SOC \leq 10\%$, Over-charged alarm.
	Protection	●	●	●	●	flashing, (Corresponding module capacity, $0\% \leq SOC \leq 5\%$ / Low voltage alarm / Over-discharge protection / Over-charge protection / Over-current alarm or protection / Hardware failure / Temperature abnormality, etc.)

2.4 Battery Management System(BMS)

2.4.1 Voltage Protection

Discharging Low Voltage Protection:

When any battery cell voltage is lower than the Rated protection value or total voltage below 42V during discharging, the over-discharging protection starts, and the battery buzzer makes an alarm sound. Then battery system stops supplying power to the outside. When the voltage of each cell recovers to rated value and total voltage restored to above 45V, the protection is released.

Charging Over Voltage Protection:

When charging, the system stops charging when the total voltage of the battery pack is higher than 54.75V or the voltage of any single cell reaches the protection value. When the total voltage returns to below 52V and the cell voltage returns to below the rated protection value, the protection is released.

2.4.2 Current Protection

Over Current Protection in Charging:

When the charging current is greater than the protection value 55A, the battery buzzer alarms and the system stops charging. After the system delays the rated time for 1min, the protection is released.

Over Current Protection in Discharging:

When the discharge current is greater than the protection value 55A, the battery buzzer alarms and the system stops discharging. After the system delays the rated time for 1min, the protection is released.



Note:

The buzzer sound alarm setting can be manually turned off on the background software, and the factory default is on.

2.4.3 Temperature Protection

Less/Over temperature protection in charging:

When battery's temperature is beyond range of 0°C~+55°C during charging, temperature protection starts, device stops charging. The protection is released when it recovers to rated return range.

Less/Over temperature protection in discharging:

When battery's temperature is beyond range of -20°C ~+55°C during discharging, temperature protection starts, device stops supplying power to the outside. The protection is released when it recovers to rated return range.

2.4.4 Other Protection

Short Circuit Protection:

When the battery is activated from the off state, if a short circuit occurs, the DC circuit breaker will act first. If the DC circuit breaker does not operate, the BMS will start the short circuit protection function and cut off the external voltage output.

Self Shutdown:

When device connects no external loads for over 72 hours, device will dormant standby automatically.



Caution

The maximum working current of the load which needs to be powered should be less than the maximum discharge current capacity of the battery system.

3 Installation and Configuration

3.1 Preparations for installation

Safety Requirement

This system can only be installed by personnel who have been trained in the power supply system and have sufficient knowledge of the power system.

The safety regulations and local safety regulations listed below should always be followed during the installation.

- All circuits connected to this power system with an external voltage of less than 48V must meet the SELV requirements defined in the IEC60950 standard.
- If operating within the power system cabinet, make sure the power system is not charged. Battery devices should also be switched off
- Distribution cable wiring should be reasonable and has the protective measures to avoid touching these cables while operating power equipment.
- when installing the battery system, must wear the protective items below:



The isolation gloves



Safety goggles



Safety shoes

3.1.1 Environmental requirements

Working temperature: $-20^{\circ}\text{C} \sim +55^{\circ}\text{C}$

- Charging temperature range is $0^{\circ}\text{C} \sim +55^{\circ}\text{C}$,
- Discharging temperature range is $-20^{\circ}\text{C} \sim +55^{\circ}\text{C}$

Storage temperature: $-10^{\circ}\text{C} \sim +35^{\circ}\text{C}$

Relative humidity: 5% ~ 85%RH

Elevation: no more than 4000m

Operating environment: Indoor or outdoor installation, sites avoid the sun and no wind, no conductive dust and corrosive gas.

And the following conditions are met:

- Installation location should be away from the sea to avoid brine and high humidity environment.
- The ground is flat and level.
- There is no flammable explosive near to the installation places.
- The optimal ambient temperature is $15^{\circ}\text{C} \sim 30^{\circ}\text{C}$
- Keep away from dust and messy zones

3.1.2 Tools and data

Hardware tool

Tools and meters that may be used are shown in table 3-1.

Table 3-1 Tool instrument

Name	
Screwdriver (word, cross)	AVO meter
wrench	clamp meter
Inclined pliers	Insulating tape
Needle nose pliers	The thermometer
Clip forceps	wrist strap
Wire stripper	AVO meter
Electric drill	Tape

3.1.3 Technical preparation

Electrical interface check

Devices that can be connected directly to the battery can be user equipment, power supplies, or other power supplies.

- Confirm whether the user equipment, the PV equipment or other power supply equipment has the DC standby interface, and measure whether the output voltage of the standby interface meets the requirements of the voltage range of table 2-2
- Verify that the maximum discharge current capacity of the user equipment, the PV equipment or other power supplies, the DC standby interface, and the maximum discharge current shall be greater than the maximum charging current of the products used in table 2-2.
- If the user equipment DC prepared interface maximum discharge capacity is less than the maximum charging current products using table 2-2, the user interface should have the power equipment of DC current limiting function, give priority to ensuring the normal work of user equipment.

The security check







- Firefighting equipment should be provided near the equipment, such as portable dry powder fire extinguisher.
- Automatic fire fighting system shall be provided for the case where necessary.
- No flammable, explosive and other dangerous articles are placed beside the battery.

3.1.4 Open the box to have inspection

- When the equipment arrives at the installation site, loading and unloading should be carried out according to the rules and regulations, so as to prevent from being exposed to sun and rain.
- Before unpacking, the total number of packages shall be indicated according to the shipping list attached to each package, and the case shall be checked for good condition.

- In the process of unpacking, handle with care and protect the surface coating of the object.
- Open the package, the professional installation person should read the technical documents, verify the list, according to the configuration table and packing list, ensure objects are complete and intact. If the internal packaging is damaged, it must be inspected and recorded in detail.

Packing list is as follows:

 <p>Battery×1</p>	 <p>Battery bottom bracket ×1</p>	 <p>Support bracket ×2</p>
 <p>M6 bolt ×8 Fixing battery box with battery bracket</p>	 <p>Power cable ×2 connect battery with inverter</p>	 <p>Communication cable</p>
 <p>M6 3 sets of combined screws x 1 (Already installed on the system cabinet) Ground wiring</p>	 <p>Expansion screw ×8</p>	 <p>Positioning cardboard×1</p>

 <p>User manual ×1</p>		
---------------------------------------------------------------------------------------------------------	--	--

3.1.5 Engineering coordination

Attention should be paid to the following items before construction:

- Power line specification.
- The power line specification shall meet the requirements of maximum discharge current for each product.
- Mounting space and bearing capacity.
- Make sure that the battery has enough room to install, and that the battery rack and bracket have enough load capacity.
- Wiring.
- Make sure the power line and ground wire are reasonable. Not easy to short-circuit, water and corrosion.

3.2 Equipment installation

The wall for battery installation shall be solid brick or cement wall with strong bearing capacity and wall thickness no less than 100mm.

Mounting space requirements:

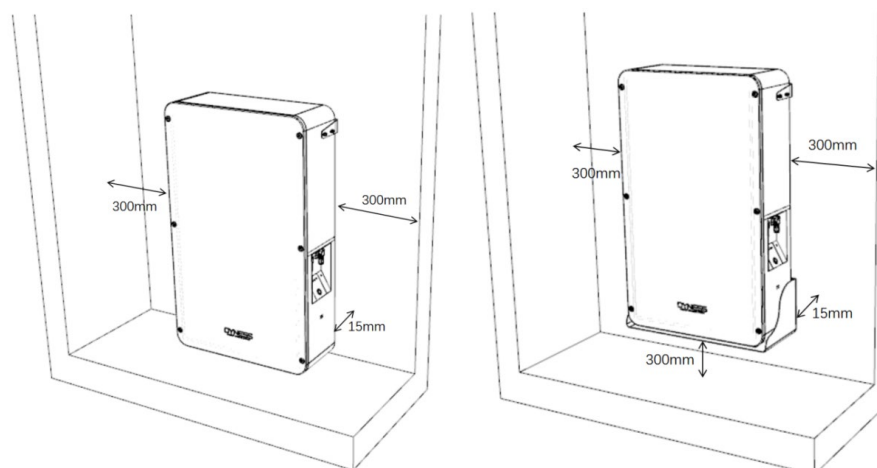

Floor installation

Mounted on the wall installation

Table 3-2 Installation steps

Step1	System outage	Ensure that the battery is in a shutdown state
Step 2	Mechanical installation	1. Hanger mounting
		2. Equipment installation
Step3	Electrical installation	1. Connect the ground cable
		2. Electrical installation
		3. Connect inverter
		4. Communication interface connection

3.2.1 Floor installation

When the battery system is placed directly on the ground, a fixed support must be used to fix the top of the battery box with the wall.



1. Use the positioning cardboard provided with the goods to draw the screw hole positions on the wall, as shown in the four holes on the left.
2. The bottom of board must be good connection with the ground level while drawing the holes.



3. 4 holes with diameter of 10mm shall be opened on the wall with electric drill according to the marked position, and the hole depth shall be greater than 70mm to fit the expansion bolts of M6.



4. Fixing the expansion bolt M6 into the bottom of the hole on the wall.
5. Use the M6 bolt to fixing the Support bracket to the wall and control the torque at 6NM.



6. Carry the battery box to the installation site, and place it about 15mm away from the vertical wall surface, fixing the Support bracket and the upper part of the battery box with M6 bolts.

3.2.2 Mounted on the wall

The following accessories need to be added when mounted the battery on the wall.



Battery bottom bracket x1



Expansion screw x4

Installation procedure

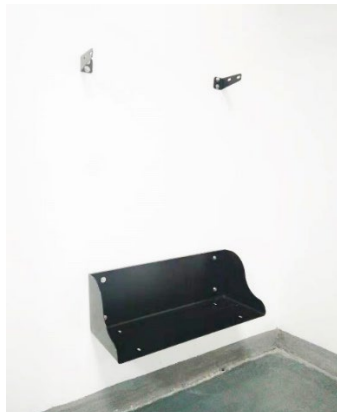

1. Use the positioning cardboard provided with the goods to draw the screw hole positions on the wall, as shown in the four holes on the left.
2. The cardboard must be perpendicular to the ground while drawing the holes.
3. The bottom of the cardboard is about 300mm from the ground.
4. According to the position of the mark, 8 holes in diameter 10mm and depth of more than 70mm are hit on the wall with an electric drill, which are used for fitting expansion bolt M6.
5. Fixing the expansion bolt M6 into the bottom of the hole on the wall, and fix the Support bracket and Battery bottom bracket on the wall with M6 bolts, twisting force keeps 6NM.
6. Carry or hoist the battery box to the installed Battery bottom bracket. Fixing the Support bracket and the upper part of the battery box with M6 bolts, twisting force keeps 6NM. Then fixing the Battery bottom bracket and the bottom part of the battery box with M6 bolts, twisting force keeps 6NM.

3.2.3 Electrical installation

Before connecting the power cables, using multimeter to measure cable continuity, short circuit, confirm positive and negative, and mark well the cable labels.

Measuring methods:

- Switch off cables: select the buzzer and use the probe to measure the ends of the same color cable. If the buzzer calls, it means the cable is available.
- Short circuit judgment: choose multimeter resistor file, probe the same end of positive and negative pole, if the resistor shows infinity, means that the cable is available.
- After visual testing of power line is connected well, the positive and negative poles of the battery shall be connected respectively to the positive and negative poles of another device.

Connect the battery box to the ground cable

Customer needs to prepare a M6 OT terminals and ground cables. Ground the battery shell as shown below. The sectional area of the grounding cable shall be at least 6mm² and the bolt locking torque is 6NM.

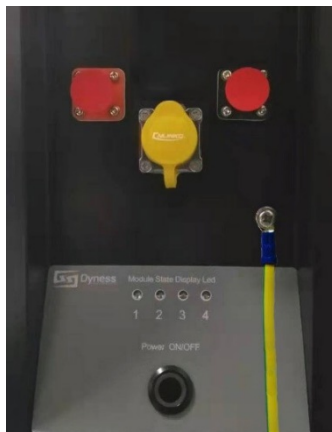

Connected inverter



Note:

If there is any question during installation, please contact your dealer to avoid damage to the equipment.

When the system is used independently:

Note: Before installation, please confirm whether the DIP switch mode of No. 1 module in POWERBOX is correct according to the inverter used. For specific dialing methods, please refer to "3.2.4 Battery module DIP switch definition and description." Except for the inverter specified by the customer's special requirements, the factory default DIP switch mode of Module No.1 is DIP Switch mode 1 (ADD: 0010). If the inverter is equipped with other DIP switch mode, open the cover and Set DIP switch mode of the

Module No.1 to the correct mode. Before opening the cover to operate, you must contact DYNESS and inform the ID of the Powerbox. DYNESS records this battery ID and authorizes the opening operation. Except changing the DIP switch mode, no other operations can be done.

- The battery is connected to the inverter, and it is required to use the dedicated power cable and communication cable (as accessories shipped with the cargo, the standard communication cable is a standard network cable. The applicable inverter is marked on the label of the network cable. If the inverter used by the customer is not covered by the standard communication cable, please contact DYNESS for the correct PIN Sequence) as follows:
- Keep the battery system at power off state, connect the power cable to the interface on the input side of the inverter first, and then connect the power cable to the interface on the battery side.
- The battery output interface is a quick connector, and the power cable (positive, negative) plug can be directly inserted into the battery socket. The power cable has a cross section of 25 mm².

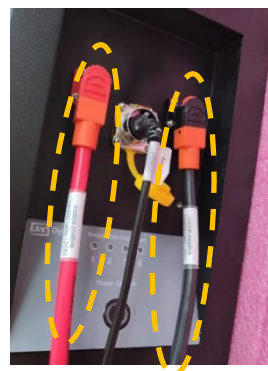

Communication port interface

Connect the CAN IN port of the battery to the CAN communication interface of the inverter using the RJ45 cable.

Factory default CAN communication mode. Alternatively, using RJ45 network wire to connect the RS485 port of the battery to the RS485 communication interface of the inverter.

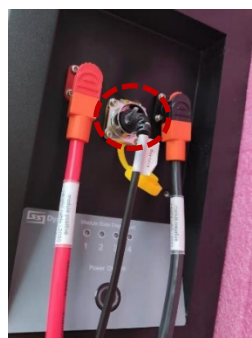
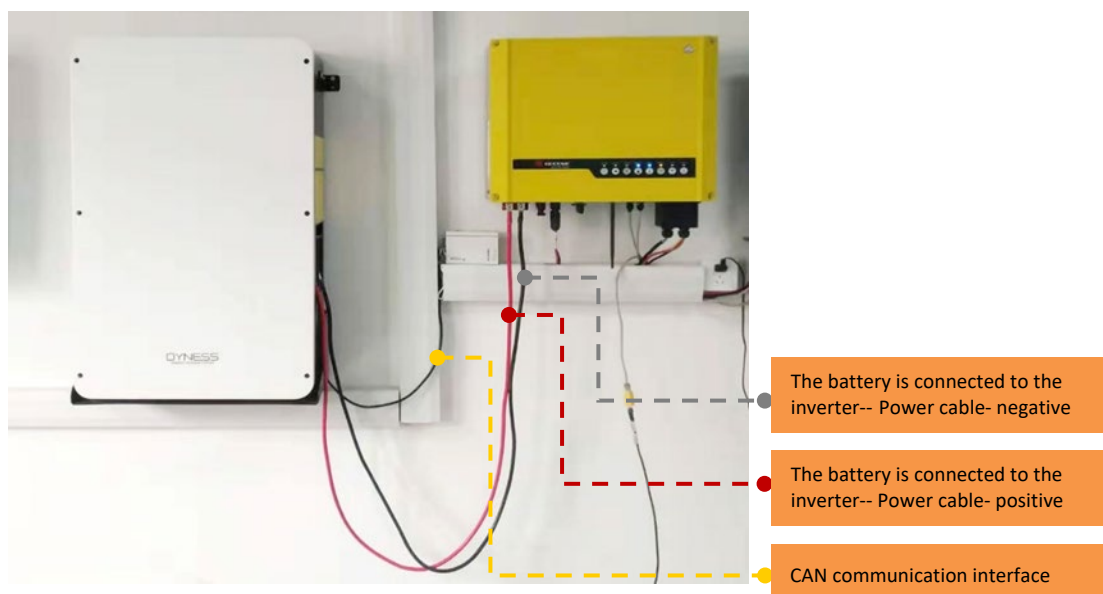



Table 3-3 Pin Definition

Foot position	Color	Definition
PIN1	Orange/white	485A
PIN2	Orange	XGND
PIN3	Green/white	485B
PIN4	Blue	CANH
PIN5	Blue/white	CANL
PIN6	Green	NC/NULL
PIN7	Brown/white	XIN
PIN8	Brown	NC/NULL



The battery is connected to the inverter-- Power cable- negative

The battery is connected to the inverter-- Power cable- positive

CAN communication interface

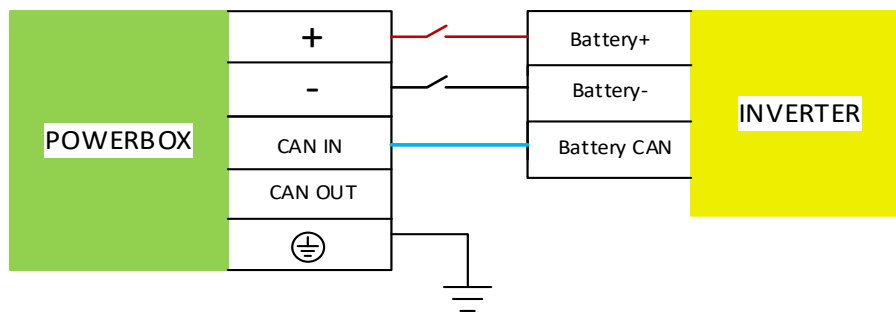

3.2.4 Battery module DIP switch definition and description

Table 3-4 Interface Definition

DIP switch position (host communication protocol and baud rate selection)			
#1	#2	#3	#4
Baud rate selection			
ON		OFF	
CAN: 250K,485: 115200		CAN: 500K,485: 9600	

DIP switch description:

For Powerbox F series system, the No. 1 module at the bottom of cabinet and near the front panel side is the host, the other modules are slaves.

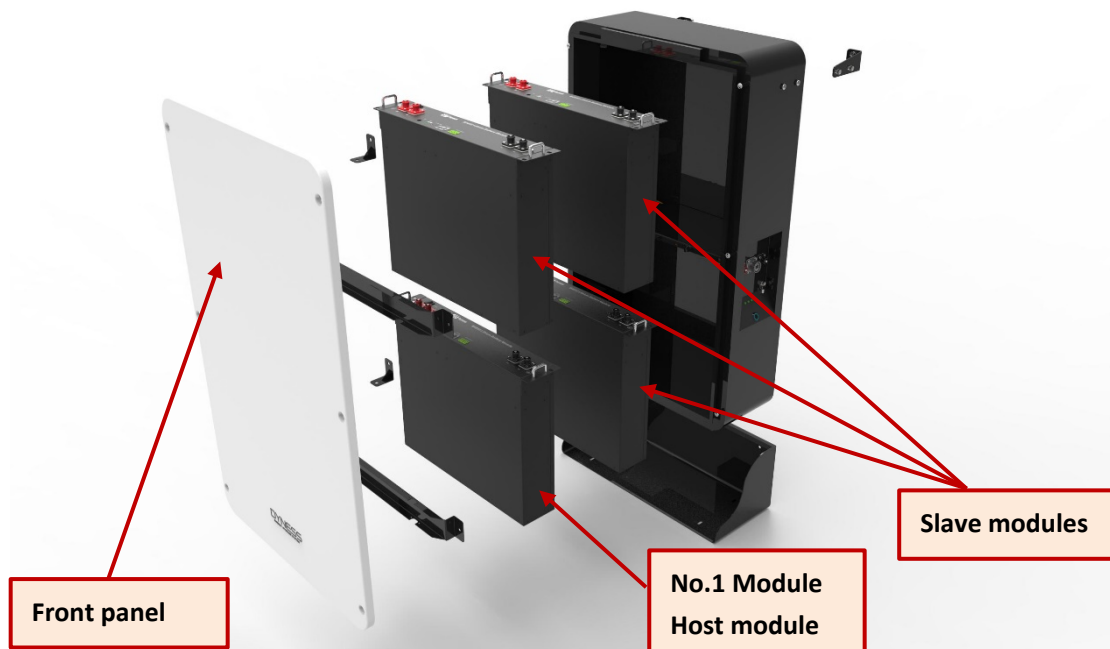

When the battery pack is connected in parallel, the host can communicate with the slave through the CAN interface. The host summarizes the information of the entire battery system and

communicates with the inverter through CAN or 485. The connection mode is divided into the following two cases:

1. If the host is the latest B4850 battery with DIP switch:

(1) The communication line that communicates with the inverter should use the one configured by Dyness.

(2) After the battery module parallel line, cascading line and communication line with GOODWE, Solis, LUX, Sofar, DEYE, VICTRON, IMEON, Voltronic (infini solar), Sungrow, RENAC and DELIOS and inverters are connected, all B4850 batteries should not be turned on first, be sure to put the host DIP switch "#3" to the "ON" position (to the top), then turn on all the B4850 batteries.



(3) If the battery module is in communication with the inverters of Growatt, GMDE, SAJ or AXPART turn the host DIP switch "#2" to "ON" position.



(4) If the battery module is in communication with the GROWATT-SPF-off-grid inverter by 485 communication, turn the host DIP switch "#2" and "#3" to "ON".



(5) The DIP switch of the slave does not need to be changed.

(6) If the energy storage system has only one B4850, it is the host itself, and still follow the above steps.

Note: For more information of matching inverter brands, please subject to the latest document <The list of compatibility between Dyness ESS and Inverters >.

2. If the host is a B4850 battery module without the DIP switch:

(1) The communication line that communicates with the inverter should use the one configured by Dyness.

(2) The battery serial number must be provided to Dyness to confirm whether the current software version of the battery system supports the inverter used.

Introduction of the initial state of DIP switch of the internal modules of Powerbox with DIP switch.

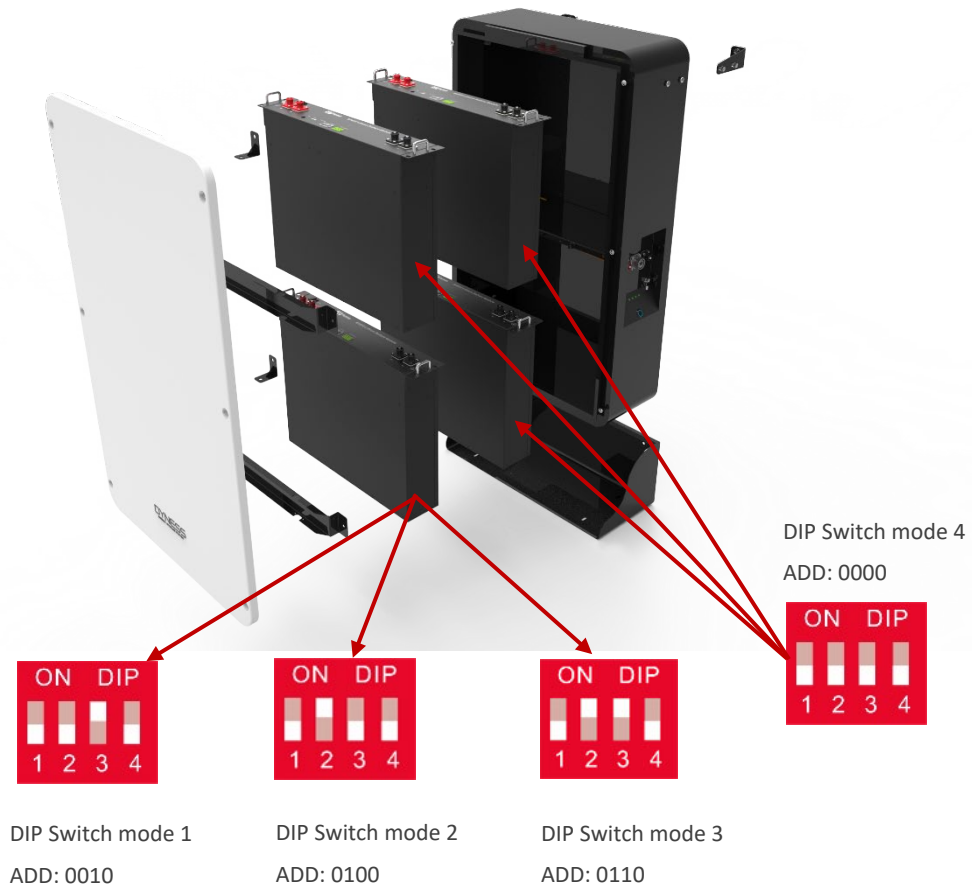

Factory default DIP switch status of No.1 B4850 battery in Powerbox is Mode 1, Mode 2 or Mode 3 (Adjust base on the different inverters).

Proceed as follows:

- a. Remove the six screws on the Powerbox and open the front cover.

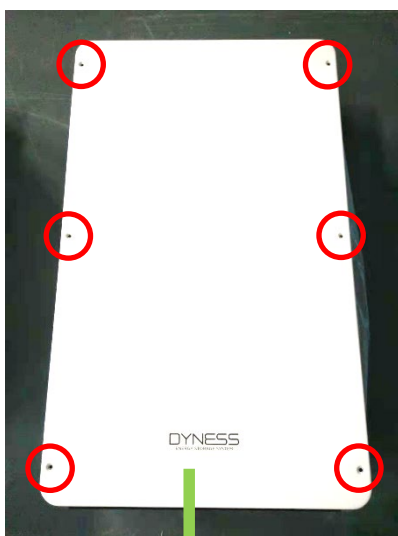

Bottom of Powerbox

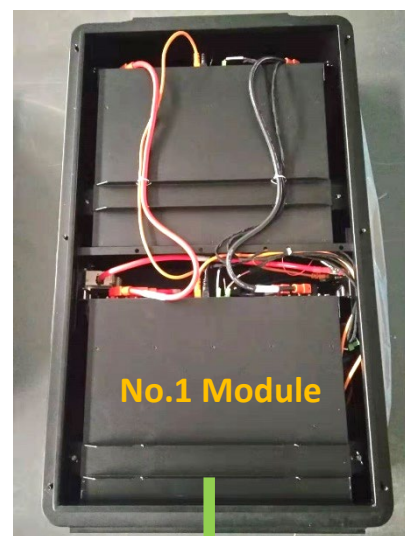

Bottom of Powerbox

- b. Find the red DIP switch on the No. 1 B4850 battery panel and confirm the status of the DIP

switch.

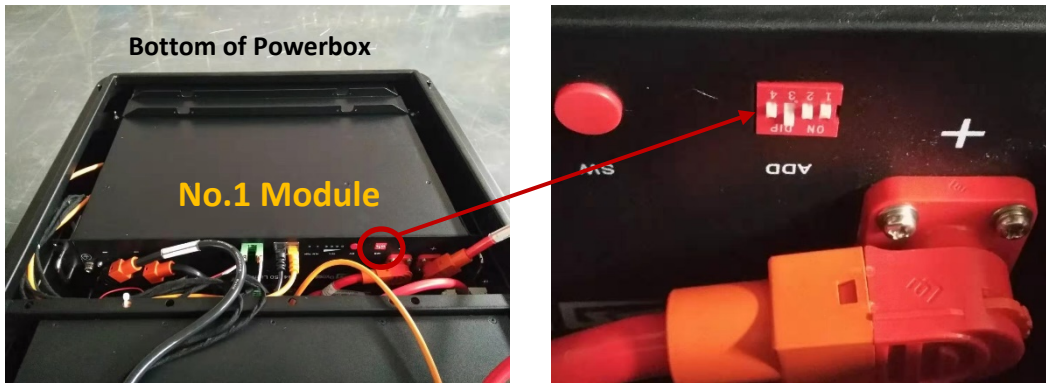

- c. Set the DIP switch status to the Original statue (Mode4: i.e. ADD: 0000)



- d. Reinstall the front cover with the six screws removed in step a.



Note:

- Before connection, the positive and negative pole of the inverter input interface and the battery output interface should be confirmed.
The red power line is connected to the positive pole and the black power line is connected to the negative pole.
- Before connection, it is necessary to confirm the charge and discharge parameters of the inverter interface.
Voltage and current should meet the requirements of Table 2-2 battery performance parameters.
- Note: For more information of matching inverter brands, please subject to the latest document <The list of compatibility between Dy Ness ESS and Inverters >.
- **The following operations can only be performed after being authorized by DYNESS:**
If there is no communication with the inverter, you can read battery information through Dy Ness Monitor, please contact Dy Ness apply for it.

Battery& Inverter power matching table

Table 3-3 Battery& Inverter power matching table

Power of Hybrid Inverter/ Off-grid Inverter	Powerbox	
	Type	System Energy (kWh)
1KW	Powerbox F-2.5	2.4
2KW	Powerbox F-5.0	4.8
3KW	Powerbox F-5.0/Powerbox F-7.5	4.8/7.2
4KW	Powerbox F-7.5/Powerbox F-10.0	7.2/9.6
5KW	Powerbox F-10.0	9.6
6KW	2 * Powerbox F-7.5	14.4
8KW	2*Powerbox F-7.5/2 * Powerbox F-10.0	14.4/19.2
10KW	2 * Powerbox F-10.0/3*Powerbox F-7.5	19.2/21.6
12KW	3 * Powerbox F-10.0	28.8

Equipment Use	Charging	a) The battery's long-term continuous charging current should be $\leq 0.5C$ b) If the battery capacity is empty, please charge it within 48 hours after the battery is empty.
	Discharging	c) The long-term continuous discharge current of the battery should be $\leq 0.5C$ d) The recommend maximum depth of discharge (DOD) of Battery PACK is no more than 90%.

4 Use, maintenance and troubleshooting

4.1 Battery system usage and operation instructions

After completing the electrical installation, follow these steps to start the battery system.

- 1 Check whether the breaker is in disconnection.



- 2 Press the battery power button, the power button LED light is on, and 4 LED indicator light will turn on the green color after self-check.



Note:

After pressing the power button, if the battery status indicator on the front panel continues to be red, please refer to the "4.2 Alarm description and processing". If the failure cannot be eliminated, please contact the dealer timely.

- 3 Use a voltmeter to measure whether the voltage across the BAT + / BAT- terminals of the inverter is greater than 42V, and check whether the voltage polarity is consistent with the input polarity of the inverter. If the voltage across the terminals

BAT + / BAT- of the inverter is greater than 42V, at this time the battery has begun to work normally.

- 4 After confirming that the battery output voltage and polarity are correct, turn on the inverter, then close the circuit breaker switch.**
- 5 Check whether the indicator light of the inverter and the battery connection (the communication indicator and the battery access status indicator) is in normal condition. If normal, the connection between the battery and the inverter is completed. If there is an abnormality in the indicator light, please check the reason or contact the local dealer with the inverter manual.**

4.2 Alarm description and processing

When protection start or failure, the ALM indicator on the front panel will alarm, through net management can query specific alarm class and take appropriate action.

4.2.1 Alarm and countermeasure influence system output

If there are any abnormalities affecting the output, such as battery cell in the battery module occurs over-voltage protection or over-current protection during charge/discharge, under-voltage protection, and temperature protection, in the system, please deal with them according to Table 4-1.

Table 4-1 Main alarm and Protection

Statue	Alarm category	Alarm indication	Processing
Charging state	Cell over-voltage	RED light flashing	Stop charging and release when discharging.
	Over-current when charging	RED light flashing	Reduce the charging current below the rated value.
	High temp protection	RED light flashing	Stop charging and find out the cause of the trouble.
Discharge state	Over-current protection when discharge	RED light flashing	Stop discharge and reduce discharge current below rated value.
	High temp protection when discharge	RED light flashing	Stop discharging and find out the cause of the trouble.
	Total voltage undervoltage protection	RED light flashing	Start charging.
	Cell voltage undervoltage protection	RED light flashing	Start charging.

4.2.2 Alarm and countermeasure without affecting the output of the system

If a low SOC alarm occurs, the battery system also issues a corresponding alarm signal. Maintainer should check the equipment according to the prompt information, determine the type and location of the fault, and take corresponding countermeasures to ensure that the system is in the best working condition to avoid affecting the system output. The phenomena and countermeasures are shown in Table 4-2.

Table 4-2 minor alarm

Alert category	Alarm indication	Countermeasure
$5\% < \text{SOC} \leq 10\%$	System working status: yellow light is always on	Stop discharge and charging the battery system in time.

4.3 Analysis and treatment of common faults

Analysis and treatment of common faults in the Table 4-3:

Table 4-3 Analysis and treatment of common faults

Item	Fault phenomenon	Reason analysis	Solution
1	The indicator does not respond after power on the system	Make sure press and hold the power switch (Reset switch) for 3s.	Check the power switch
2	No DC output after power on the system	Check if the side DC circuit breaker is closed	Check the status of the side DC circuit breaker
3	No DC output and red light flashing	Battery voltage is too low	Charging the battery system
4	The battery cannot be fully charged	Charging voltage is too low	Adjust charging voltage within 53.5V range
5	The power line sparks once power on and ALM indicated Red light on	Power connection short-circuit	Turn off the battery, check the cause of the short circuit

If you have any technical help or question, please contact the seller in time.



Jiangsu Daqin New Energy Tech Co., Ltd
Address: 158# South Ji'an Road, Hi-Tech District,
Yangzhou City, Jiangsu Province, China, 211400.
Email: sales@dyness.net
Website: www.dyness.net